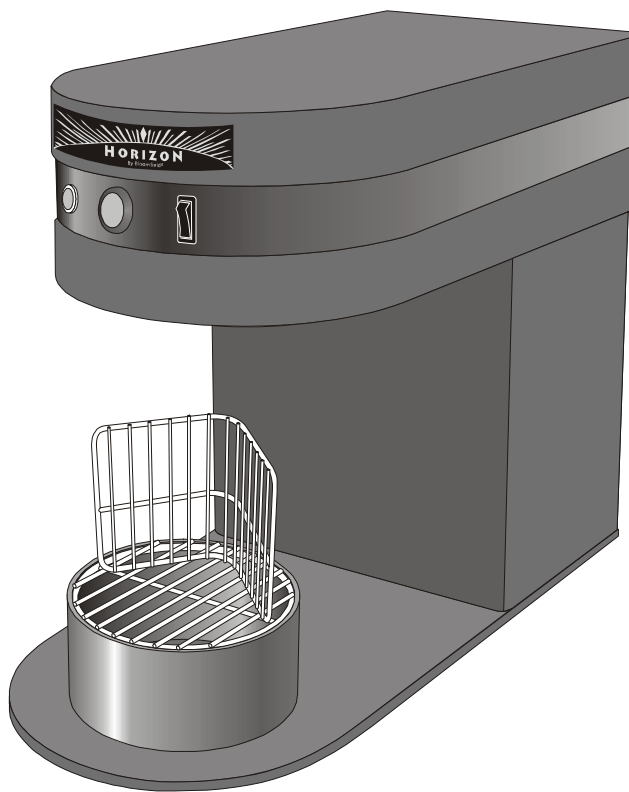

BLOOMFIELD INDUSTRIES

2 ERIK CIRCLE, P. O. Box 280
Verdi, NV 89439
telephone: 775-689-5700
fax: 888-492-2783
www.wellsbloomfield.com

**OWNERS MANUAL
For****HOT WATER
DISPENSER****MODELS:****0401 Hot Water Dispenser****Includes:****Installation
Operation
Use & Care
Servicing Instructions**

Model: 0401

PRINTED IN CHINA

WARRANTY STATEMENT

All electrical equipment manufactured by BLOOMFIELD INDUSTRIES is warranted against defects in materials and workmanship for a period of one year from the date of original installation or eighteen (18) months from the date of shipment from our factory, whichever comes first, and is for the benefit of the original purchaser, except that:

- a. airpots carry a 30 day parts warranty only.
- b. dispensers; i.e., tea and coffee carry a 90 days parts warranty only, excludes decanters.

THE FOREGOING OBLIGATION IS EXPRESSLY GIVEN IN LIEU OF ANY OTHER WARRANTIES, EXPRESSED OR IMPLIED, INCLUDING ANY IMPLIED WARRANTY OF MERCHANTABILITY OR FITNESS FOR A PARTICULAR PURPOSE, WHICH ARE HEREBY EXCLUDED.

BLOOMFIELD INDUSTRIES DIVISION / CARRIER COMMERCIAL REFRIGERATION SHALL NOT BE LIABLE FOR INDIRECT, INCIDENTAL OR CONSEQUENTIAL DAMAGES OR LOSSES FROM ANY CAUSE WHATSOEVER.

This warranty is void if it is determined that upon inspection by an Authorized Service Agency that the equipment has been modified, misused, misapplied, improperly installed, or damaged in transit or by fire, flood or act of God.

It also does not apply if the serial nameplate has been removed or unauthorized service personnel perform service. The prices charged by Bloomfield Industries for its products are based upon the limitations in this warranty. Seller's obligation under this warranty is limited to the repair of defects without charge by a Bloomfield Industries Authorized Service Agency or one of its sub-agencies. This service will be provided on customer's premises for non-portable models. Portable models (a device with a cord and plug) must be taken or shipped to the closest Authorized Service Agency, transportation charges prepaid, for services.

In addition to restrictions contained in this warranty, specific limitations are shown below (Additional Warranty Exclusions). Bloomfield Industries Authorized Service Agencies are located in principal cities.

This warranty is valid in the United States and void elsewhere. Please consult your classified telephone directory or your food service equipment dealer; or, for information and other details concerning warranty, write to:

**Service Parts Department
Bloomfield Industries
P.O. Box 280
Verdi, NV 89439**

Phone: (888) 492-2782

Fax: (888) 492-2783

SERVICE POLICY AND PROCEDURE GUIDE ADDITIONAL WARRANTY EXCLUSIONS

1. Resetting of safety thermostats, circuit breakers, overload protectors, or fuse replacements unless warranted conditions are the cause.
2. All problems due to operation at voltages other than specified on equipment nameplates; conversion to correct voltage must be the customer's responsibility.
3. All problems due to electrical connections not made in accordance with electrical code requirements and wiring diagrams supplied with the equipment.
4. Replacement of items subject to normal wear, to include such items as knobs and light bulbs. Normal maintenance functions including adjustment of thermostats, microswitches, and replacement of fuses and indicating lights are not covered under warranty.
5. All problems due to inadequate water supply, such as fluctuating, or high or low water pressure.
6. All problems due to mineral/calcium deposits, or contamination from chlorides/chlorines. De-liming is considered a preventative maintenance function and is not covered by warranty.
7. Full use, care and maintenance instructions are supplied with each machine. Those miscellaneous adjustments noted are customer responsibility. Proper attention will prolong the life of the machine.
8. Travel mileage is limited to sixty (60) miles from an authorized Service Agency or one of its sub-agencies.
9. All labor shall be performed during normal working hours. Overtime premium shall be charged to the customer.
10. All genuine Bloomfield replacement parts are warranted for ninety (90) days from date of purchase on non-warranted equipment. **Any use of non-genuine Bloomfield parts completely voids any warranty.**
11. Installation, labor and job check-out are not considered warranty.
12. Charges incurred by delays, waiting time or operating restrictions that hinder the service technicians ability to perform services are not covered by warranty. This includes institutional and correctional facilities.

SHIPPING DAMAGE CLAIMS PROCEDURE

NOTE: For your protection, please note that equipment in this shipment was carefully inspected and packaged by skilled personnel before leaving the factory. Upon acceptance of this shipment, the transportation company assumes full responsibility for its safe delivery.

IF SHIPMENT ARRIVES DAMAGED:

1. **VISIBLE LOSS OR DAMAGE:** Be certain that any visible loss or damage is noted on the freight bill or express receipt, and that the note of loss or damage is signed by the delivery person.
2. **FILE CLAIM FOR DAMAGE IMMEDIATELY:** Regardless of the extent of the damage.

3. **CONCEALED LOSS OR DAMAGE:** if damage is unnoticed until the merchandise is unpacked, notify the transportation company or carrier immediately, and file "CONCEALED DAMAGE" claim with them. This must be done within fifteen (15) days from the date the delivery was made to you. Be sure to retain the container for inspection.

Bloomfield Industries cannot assume liability for damage or loss incurred in transit. We will, however, at your request, supply you with the necessary documents to support your claim.

TABLE OF CONTENTS

WARRANTY STATEMENT	xi	Thank You for purchasing this Bloomfield Industries appliance.
SPECIFICATIONS	1	
FEATURES & OPERATING CONTROLS	2	
PRECAUTIONS & GENERAL INFORMATION	3	Proper installation, professional operation and consistent maintenance of this appliance will ensure that it gives you the very best performance and a long, economical service life.
AGENCY LISTING INFORMATION	3	
INSTALLATION INSTRUCTIONS	4	
OPERATION	7	
CLEANING INSTRUCTIONS	9	
TROUBLESHOOTING SUGGESTIONS	10	This manual contains the information needed to properly install this appliance, and to use, care for and maintain or repair the appliance in a manner which will ensure its optimum performance.
SERVICING INSTRUCTIONS	11	
Deliming Instructions	14	
WIRING DIAGRAMS	15	
EXPLODED VIEW & PARTS LIST	16	

SPECIFICATIONS

MODEL	STYLE	VOLTS	WATTS	AMPS 1ø	POWER SUPPLY CORD
0401	HOT WATER DISPENSER	120	1800	15.0	NEMA 5-15P
☁0401CA			1500	12.5	

☁ meets Canadian Standards

APPLICABILITY

This manual applies to the following Bloomfield Industries products:
0401, 0401CA, 0401PE

FEATURES AND OPERATING CONTROLS - HOT WATER DISPENSER

MODEL 0401

0482 CONTROL PANEL

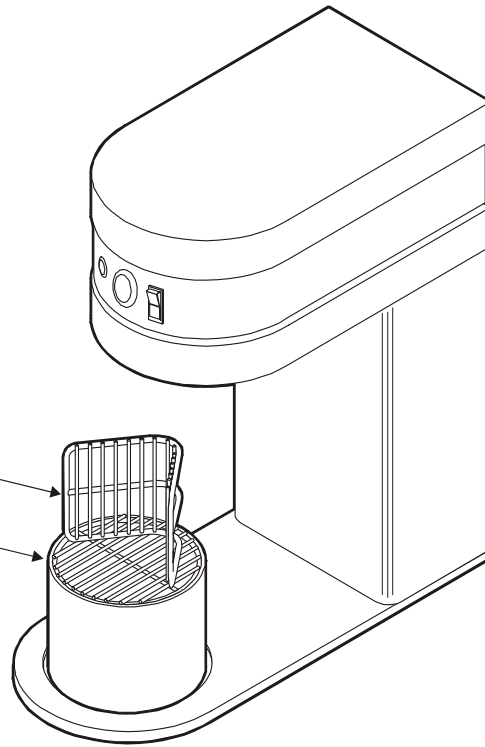
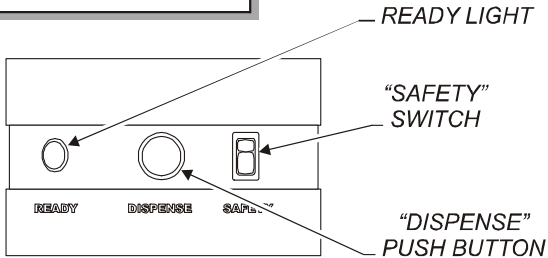

TYPICAL REAR VIEW

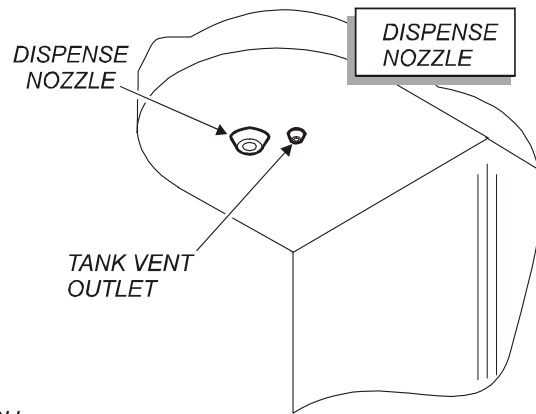
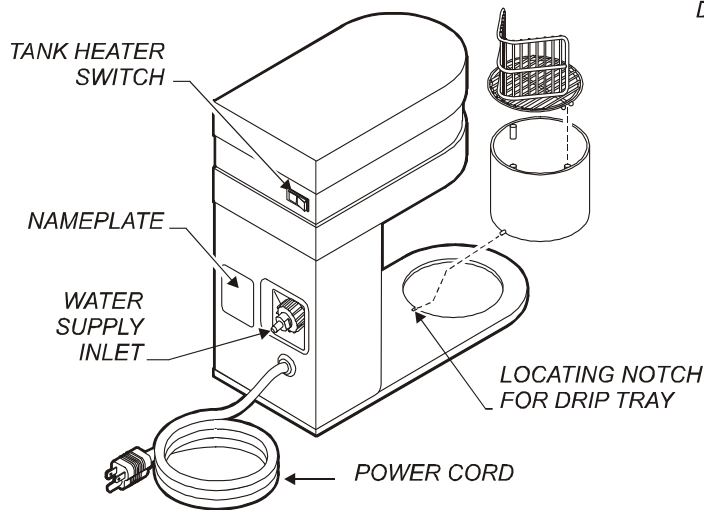

685 77110 Owners Manual Horizon™ Brewers

Fig. 1 Features & Operating Controls

PRECAUTIONS AND GENERAL INFORMATION



WARNING: ELECTRIC SHOCK HAZARD

All servicing requiring access to non-insulated components must be performed by qualified service personnel. Do not open any access panels which require the use of tools. Failure to heed this warning can result in electrical shock.



WARNING: INJURY HAZARD

All installation procedures must be performed by qualified personnel with full knowledge of all applicable electrical and plumbing codes. Failure could result in property damage and personal injury.



WARNING: ELECTRIC SHOCK HAZARD

Dispenser must be properly grounded to prevent possible shock hazard. DO NOT assume a plumbing line will provide such a ground. Electrical shock will cause death or serious injury.



WARNING: BURN HAZARD

This appliance dispenses very hot liquid. Serious bodily injury from scalding can occur from contact with dispensed liquids.

This appliance is intended for commercial use only.

This appliance is intended for use to dispense hot water for human consumption. No other use is recommended or authorized by the manufacturer or its agents.

The following trouble shooting, component views and parts lists are included for general reference, and are intended for use by qualified service personnel.

This manual should be considered a permanent part of this appliance. The manual must remain with the appliance if it is sold or moved to another location.



CAUTION: ELECTRICAL DAMAGE

DO NOT plug in or energize this appliance until all *Installation Instructions* are read and followed. Damage to the Brewer will occur if these instructions are not followed.

AGENCY LISTING INFORMATION

This brewer is  and  listed under UL file E9253.

This brewer meets  Standard 4 only when installed, operated and maintained in accordance with the enclosed instructions.



E9253



E9253



STD 4

INSTALLATION

READ THIS CAREFULLY BEFORE STARTING THE INSTALLATION

IMPORTANT:

To enable the installer to make a quality installation and to minimize installation time, the following suggestions and tests should be done before the actual unit installation is started:

Unpack the unit. Inspect all components for completeness and condition. Ensure that all packing materials have been removed from the unit.

LEVELING THE UNIT

Set Dispenser on a solid level surface.

Be sure all four feet touch the counter to prevent tipping.



CAUTION: ELECTRICAL DAMAGE

DO NOT plug in or energize this appliance until all Installation Instructions are read and followed. Damage to the Dispenser will occur if these instructions are not followed.



CAUTION: UNSTABLE EQUIPMENT HAZARD

It is very important for safety and for proper operation that the brewer is level and stable when standing in its final operating position. Failure to provide a stable, level counter for the dispenser will result in movement of the dispenser which can cause personal injury and/or property damage.

READ THIS CAREFULLY BEFORE STARTING THE INSTALLATION

PLUMBER'S INSTALLATION INSTRUCTIONS

Dispenser should be connected to a **POTABLE WATER, COLD WATER** line. Flush water line before connecting to Dispenser.

DO NOT use a saddle valve with a self-piercing tap for the water line connection. Such a tap can become restricted by waterline debris. For systems that must use a saddle tap, shut off the main water supply and drill a 3/16" (minimum) tap for the saddle connection, in order to insure an ample water supply. Remember to flush the line prior to installing the saddle.

The Dispenser must be installed on a water line with average pressure between 20 PSI and 90 PSI. If your water pressure exceeds 90 PSI at anytime, a pressure regulator must be installed in the water supply line to limit the pressure to not more than 90 PSI in order to avoid damage to lines and solenoid.

A water shut-off valve should be installed on the incoming water line in a convenient location (Use a low restriction type valve, such as a 1/4-turn ball valve, to avoid loss of water flow thru the valve.

NSF requires that the Dispenser be able to be moved for cleaning underneath. Loops of copper tubing will satisfy this requirement. See Figure 2 below.

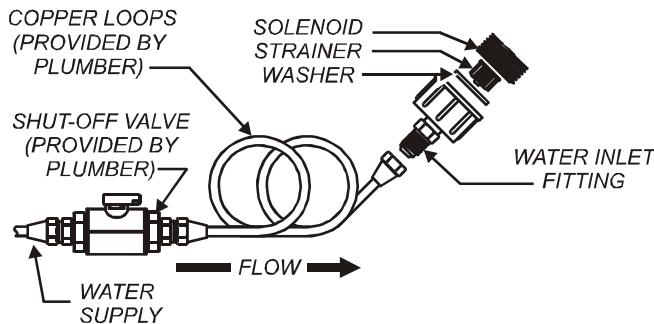

Fig. 2 Water Supply Installation

In some areas, local codes require a backflow preventer (check valve) to be installed on the inlet water line. If a backflow preventer is used, you must install a *water hammer arrester* in the incoming line, between the backflow preventer and the Dispenser water inlet, as far away from the Dispenser as space will allow. This will relieve the excessive back pressures that can cause leaks and solenoid malfunctions.



**CAUTION:
ELECTRICAL
DAMAGE**

DO NOT plug in or energize this appliance until all Installation Instructions are read and followed. Damage to the Brewer will occur if these instructions are not followed.

IMPORTANT:

Tank must be full of water before connecting dispenser to electric power. Heating elements will be damaged if allowed to operate without being fully submerged in water. See instructions for filling tank, page 7. Damage caused by operating the dispenser without water in the tank is **NOT COVERED BY WARRANTY**.

NOTE: Water supply inlet line must meet certain minimum criteria to insure successful operation of the brewer. Bloomfield recommends 1/4" copper tubing for installation of less than 12 feet and 3/8" for more than 12 feet from a 1/2" water supply line.

NOTE: This equipment must be installed to comply with applicable federal, state and local plumbing codes and ordinances.

INSTALLATION (continued)



WARNING: **SHOCK HAZARD**

Dispenser must be properly grounded to prevent possible shock hazard. DO NOT assume a plumbing line will provide such a ground. Electrical shock will cause death or serious injury.

IMPORTANT:

Supply power must match nameplate for voltage and phase. Connecting to the wrong voltage will damage the Dispenser or result in decreased performance. Such damage is not covered by warranty.

IMPORTANT:

Do not connect Dispenser to electrical power until you have filled the tank. See instructions on page 7.

IMPORTANT:

The ground prong of the plug is part of a system designed to protect you from electrical shock in the event of internal damage. Never cut off the ground prong nor twist a blade to fit an existing receptacle. Contact a licensed electrician to install the proper circuit and receptacle.

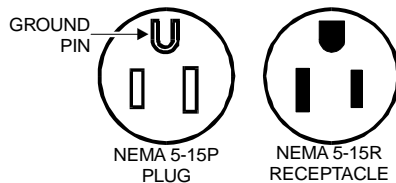

Fig. 3 Power Supply Plug

ELECTRICIAN'S INSTALLATION INSTRUCTIONS

REFER TO ELECTRICAL SPECIFICATIONS - Page 1
Check the nameplate to determine correct electrical service required for the Dispenser to be installed.

IMPORTANT: Before connecting to electricity, make sure Dispenser is connected to the water supply.

Dispenser is equipped with a cord and plug. It will require a 115 - 125 volt 20 amp circuit (50/60 Hz, 2 wire plus ground, with NEMA 5-15R Receptacle).

See Figure 3 at left.

A. START-UP

For initial start-up, or if the dispenser has not been used for an extended period of time:

- ◆ Be sure the water supply is properly connected and the water supply valve is turned *ON*.
- ◆ Be sure the WATER TANK IS FILLED.

IMPORTANT: Fill the water tank before energizing this dispenser.

1. Verify the water supply is properly connected and the water supply valve is turned *ON*.
2. Be sure the TANK HEATER SWITCH is *OFF* before connecting the dispenser to electric power. Plug the power cord into an appropriate electrical receptacle.
3. Allow the tank to fill for several minutes. Place an empty container under the dispense nozzle.

Press and hold the SAFETY switch, then press the DISPENSE push-button. When water flows from the nozzle in a steady stream, tank is full.

4. Press the TANK HEATER SWITCH *ON*. When READY light glows, unit is ready for use.
5. Be sure the DRIP TRAY is empty and the CUP GRID is properly installed. Locate the cup grid and drip tray in place under the dispense nozzle.

B. USING THE DISPENSER

Place a cup on the cup grid. **DO NOT** hold cup while filling.

Press and hold SAFETY switch.

Press DISPENSE push-button. Release when water in cup reaches desired level. Release SAFETY switch. Remove cup from cup grid. Be careful not to spill or splash water from cup

IMPORTANT:
TANK MUST BE FULL OF WATER BEFORE CONNECTING BREWER TO ELECTRIC POWER.

Heating elements will be damaged if allowed to operate without being fully submerged in water. Damage caused by operating the brewer without water in the tank is *NOT COVERED BY WARRANTY*.



CAUTION:
BURN HAZARD

This appliance dispenses very hot liquid. Serious burns can occur from contact with dispensed liquids. **DO NOT** hold cup while filling. **DO NOT** spill or splash water from cup.

OPERATION

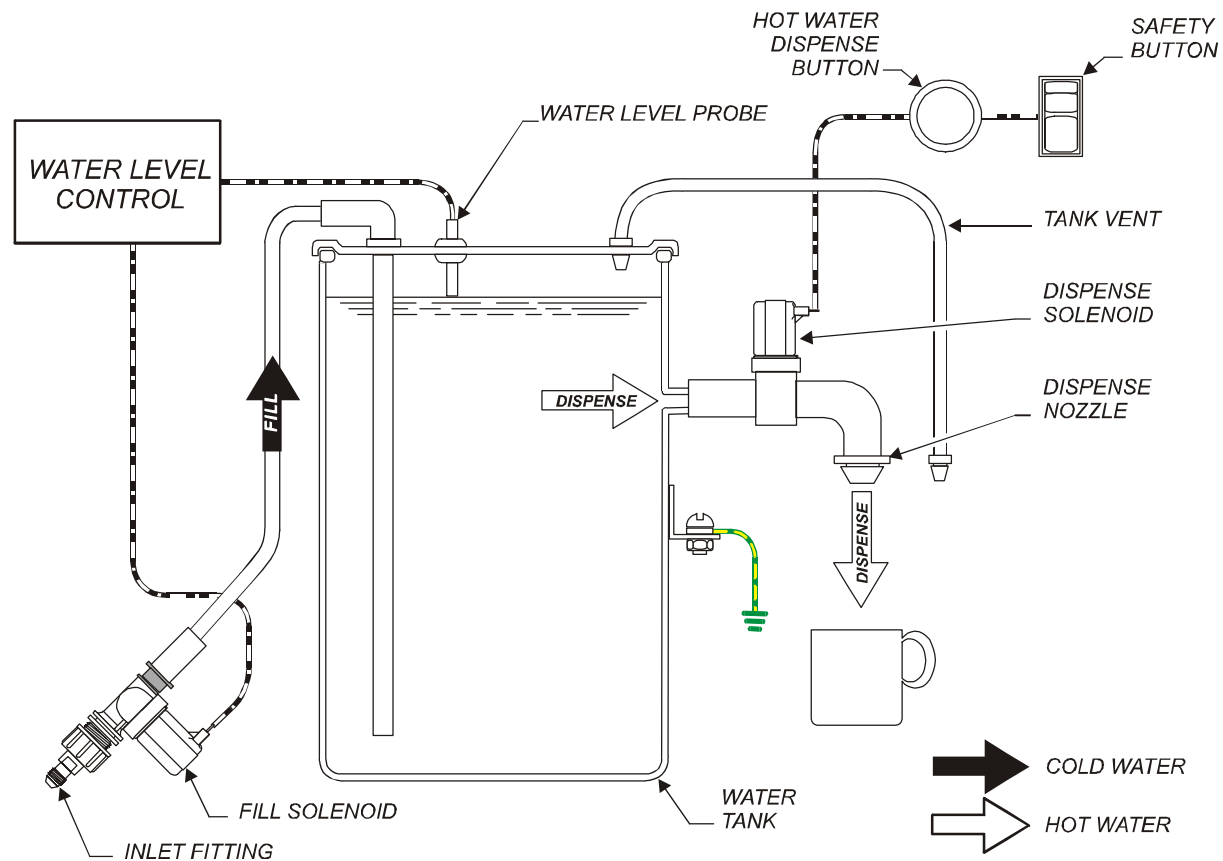

Fig. 4 Dispenser Operation Diagram

WATER HEATER

Water temperature is sensed by thermobulb inserted into the water tank. Temperature is controlled by a mechanical thermostat.

The setpoint temperature is adjustable by turning the thermostat shaft.

Excessive temperature will trip the hi-limit safety switch, disabling the heating element. The hi-limit will automatically reset when the dispenser cools.

WATER LEVEL

Water level is controlled by an electronic controller. The water level probe senses chassis ground through the water. When the water level is below the probe no ground is sensed. The controller opens the fill solenoid until the water level makes contact with the probe.

DISPENSING

Heated water flows from the tank to the dispense nozzle through an electrically controlled solenoid.

Both the safety switch and the dispense push-button must be pressed at the same time in order to activate the dispense solenoid.

CLEANING INSTRUCTIONS

PROCEDURE: Clean Hot Water Dispenser

PRECAUTIONS: Disconnect dispenser from electric power.
Allow dispenser to cool.

FREQUENCY: Daily

TOOLS: Mild Detergent, Clean Soft Cloth or Sponge
Bristle Brush

1. Disconnect dispenser from electric power.
Allow to cool before cleaning.
Remove cup grid & drip tray
2. Wipe exterior of dispenser with a soft clean cloth or sponge moistened with mild detergent and clean water. Rinse by wiping with a soft clean cloth or sponge moistened clean water.
3. Wipe dispense nozzle to remove any mineral deposits. A bristle brush may be used to remove stubborn mineral build-up.
4. Empty drip tray. Drip tray and cup grid may be washed in the sink with warm water and mild detergent if necessary. Rinse with clean water and allow to air dry.
5. Reassemble cup grid to drip tray, then reinstall under dispense nozzle

Procedure is complete



CAUTION:
Burn Hazard

Dispensed water is extremely hot. Hot water will cause serious skin burns.



CAUTION:
Electric Shock Hazard

Do not submerge or immerse dispenser in water.

IMPORTANT:

DO NOT use steel wool, sharp objects, or caustic, abrasive or chlorinated cleansers to clean the dispenser's stainless steel surfaces.

TROUBLESHOOTING SUGGESTIONS

SYMPTOM	POSSIBLE CAUSE	SUGGESTED REMEDY
Water won't heat	Dispenser unplugged or circuit breaker tripped	Check power supply cord Check / reset circuit breaker
	Tank heater switch "OFF"	Press switch to "ON"
	Temperature setpoint too low	Adjust thermostat for desired temperature
	Hi-Limit safety switch tripped	Allow to cool hi-limit will self-reset
	Damaged internal component or wiring	Examine wiring & connectors, controller, power board and heating element Repair/replace as needed
No flow from dispense nozzle	Water supply OFF	Turn water supply ON
	Inlet solenoid strainer plugged	Clean strainer
	Dispense solenoid damaged	Replace dispense solenoid
	Water level probe grounded	Check / repair wiring to probe Check / replace probe sleeve Replace probe
	Water level controller damaged	Check / repair controller wiring Replace controller
Dispense nozzle drips	Debris in dispense solenoid	Replace dispense solenoid
	Debris in fill solenoid seat (drips from vent tube)	Replace inlet solenoid
Unit overfills	Water level probe out of place or coated with minerals	Clean, reinstall or replace water level probe
	Wiring loose or damaged	Repair or replace wiring as required. Carefully examine ground connection for tightness
	Controller damaged	Replace controller

7145 77380 Owners Manual Horizon™ Q401 Hot Water Dispenser

SERVICING INSTRUCTIONS

TEMPERATURE ADJUSTMENT

Disconnect dispenser from electric power. Remove top panel.

Pull vent tube out of tank lid and insert a thermometer of known accuracy in hole. Reconnect dispenser to electrical power. Place empty container under dispense nozzle.

Energize dispenser and allow unit to heat. When READY light glows, read the temperature displayed on thermometer.

Adjust thermostat by turning shaft; clockwise increases temperature. 1/8 turn = approximately 10°F.

Refer to Table 1 below for proper brewing temperature based on altitude.

Upon completion, remove thermometer and reinstall the vent tube.

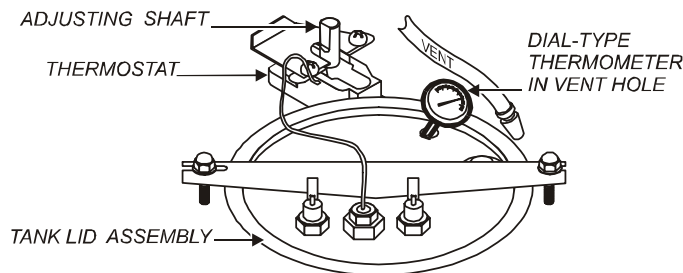

Fig. 5 Checking and Adjusting Water Temperature

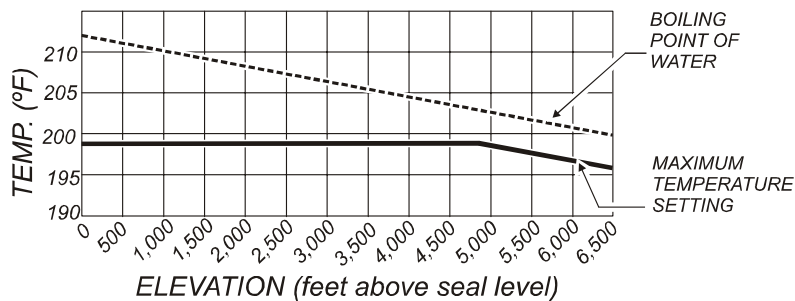

Table 1 Boiling Temperature by Altitude



CAUTION: SHOCK HAZARD

These procedures involve exposed electrical circuits. These procedures are to be performed by qualified technical personnel only.

IMPORTANT:

A mechanical thermostat will maintain temperature within $\pm 5^\circ\text{F}$. To prevent boiling water in the brewer, thermostat should be adjusted to a maximum temperature equal to the local boiling temperature minus 5°F .

SERVICING INSTRUCTIONS (continued)

IMPORTANT:

Water pressure must be between 20 p.s.i and 90 p.s.i. flowing pressure. If water pressure exceeds this value, or if water pressure varies greatly, a pressure regulator must be installed in the water supply line.

IMPORTANT:

Before setting assembly into tank, make sure tank lid gasket is properly seated on flange of lid. *DO NOT OVER-TIGHTEN.*

IMPORTANT:

When mounting thermostat, be sure to insert sensing bulb to the bottom of the bulb well. Tighten capillary lock nut only enough to ensure no water leakage. Excessive tightening is not necessary.

IMPORTANT:

When replacing heating element, also replace seal gaskets.

REMOVE TANK LID ASSEMBLY

Disconnect dispenser from electric power. Turn *OFF* water supply. Remove top panel. Pull vent tube and inlet elbow out of tank lid.

Disconnect all wiring from thermostat, hi-limit, and heating element. Loosen and free jam nut from pass-thru fitting securing temperature sensing bulb to tank lid. Remove bulb from tank lid.

Loosen two nuts on tank hold-down bracket. Remove hold-down bracket by sliding short slotted end off of locking stud and lifting it off. Remove cover assembly by lifting it straight up.

Reassemble in reverse order.

REPLACE THERMOSTAT

Disconnect dispenser from electric power. Turn *OFF* water supply. Remove top panel. Remove mounting screw from terminal block and position terminal block out of the way.

Disconnect all wiring from thermostat only. Loosen and free jam nut from pass-thru fitting securing temperature sensing bulb to tank lid. Remove two screws holding thermostat to bracket.

Lift out thermostat, sensing bulb and bulb well.

Reassemble in reverse order. **BE SURE** the bulb well is fully seated in the tank fitting, and that the temperature sensing bulb is inserted to the very bottom of the bulb well.

REPLACE HEATING ELEMENT

Remove tank lid assembly per above.

Remove two hex nuts holding element to cover. Pull element from mounting holes.

Reassemble in reverse order.

REPLACE BREW READY LIGHT, SAFETY SWITCH or DISPENSE PUSH-BUTTON

Unplug power cord. Disconnect electric leads from light. Or switch.

Using a thin screwdriver, compress mounting tabs then pry light or switch from mounting hole.

Reassemble in reverse order.

SERVICING INSTRUCTIONS (continued)

REPLACE FILL SOLENOID

IMPORTANT: Shut-off water and disconnect dispenser from electric power before removing hoses or wiring.

Remove top cover and detach solenoid access door from cabinet.

Remove water supply inlet flare fitting

Note: Service wrench #86660 is designed to hold the flats of the solenoid inlet fitting while attaching or removing the flare nut.

- a. Slide the 5/8" end of wrench #86660 over the flats on the valve inlet fitting
- b. Hold the wrench to prevent the inlet fitting from turning while installing or removing the inlet water supply flare nut.

Disconnect wiring.

Remove two screws holding solenoid to access door.

Reassemble in reverse order.

REPLACE DISPENSE SOLENOID

Disconnect dispenser from electric power. Turn *OFF* water supply. Remove top panel. Remove mounting screw from terminal block and position terminal block out of the way.

Disconnect wiring from dispense solenoid.

Slide hoses from solenoid. Remove two screws holding solenoid to bracket.

Reassemble in reverse order.

CLEAN SOLENOID SCREEN

Symptom: Dispenser will not flow water.

Disconnect dispenser from electric power. Turn *OFF* and disconnect water supply from dispenser inlet fitting.

Unscrew water inlet fitting from solenoid.

Using needle-nose pliers, withdraw strainer screen from solenoid. Clean screen under faucet. A stiff bristle brush may be used if necessary.

Reinsert screen in solenoid. Be careful to maintain correct orientation. (The *OPEN END* of the screen goes in *FIRST*.)

Reassemble in reverse order.

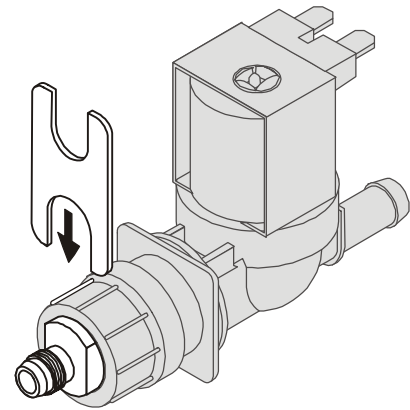

Fig. 6 Use wrench #86660 to Attach or Undo the Inlet Fitting Flare Connection

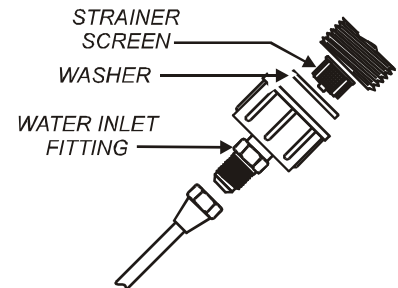

Fig. 7 Clean Inlet Solenoid Strainer Screen

SERVICING INSTRUCTIONS (continued)



CAUTION: **CHEMICAL BURN** **HAZARD**

Deliming chemicals may be caustic. Wear appropriate protective gloves and goggles during this procedure.

Never siphon deliming chemicals or solutions by mouth.

This operation should only be performed by qualified and experienced service personnel.

IMPORTANT: DO NOT spill, splash or pour water or deliming solution into or over any internal component other than the inside of the water tank.

IMPORTANT: DO NOT allow any internal components to come into contact with the deliming solution. Take care to keep all internal components dry.

NOTE: Repeat steps 4 thru 5 as required to remove all scale and lime build-up.

NOTE: Normally, silicone hoses do not need to be delimed. Should deliming hoses become necessary, Bloomfield recommends replacing the hoses.

PROCEDURE: Delime the Water Tank

PRECAUTIONS: Disconnect dispenser from electric power. Allow dispenser to cool.

FREQUENCY: As required (Dispenser slow to heat)

TOOLS: Deliming Solution
Protective Gloves, Goggles & Apron
Mild Detergent, Clean Soft Cloth or Sponge
Bristle Brush, Bottle Brush
Large Sink (or other appropriate work area)

1. Disconnect dispenser from electric power. Disconnect the water supply line from the inlet fitting.
2. Remove the tank lid assembly as described on page 12.
3. Remove two screws holding tank to dispenser cabinet. Remove the water tank from the dispenser body by lifting straight up. Disconnect chassis ground lead from tank. Empty all water from the tank. Set the tank back into the unit.
4. Mix 2 quarts of deliming solution according to the manufacturer's directions. Carefully pour the deliming solution into the water tank. Lower the lid assembly back onto the tank. Allow to sit for 30 minutes, or as directed by the manufacturer.
5. At end of soaking period, remove lid assembly from tank. Thoroughly rinse internal components of lid assembly with clear water. Using a stiff bristle brush, scrub the heating element to remove lime and calcium build-up. Rinse with clean water. Store lid assembly in a safe location.
6. Remove the tank from the dispenser and empty. Using a stiff bristle brush, scrub the interior of the water tank to remove lime and calcium build-up. Rinse with clean water.
7. Reconnect the chassis ground lead and set the tank back into the dispenser. Install the two mounting screws. Reassemble the tank lid to the water tank. Make sure the gasket is properly in place, then reinstall the hold-down strap.
8. Reinstall wiring to heating element and thermostat. Reinstall the hi-limit thermostat (if removed). Verify that all internal components are dry, then reinstall the top panel.
10. Reconnect dispenser to electrical supply and reconnect water supply.
11. Place an empty container under the dispense nozzle. Dispense at least 10 full cups of water and discard all water generated.
12. Dispenser is ready to use.

WIRING DIAGRAM

MODEL 0401 HOT WATER DISPENSER

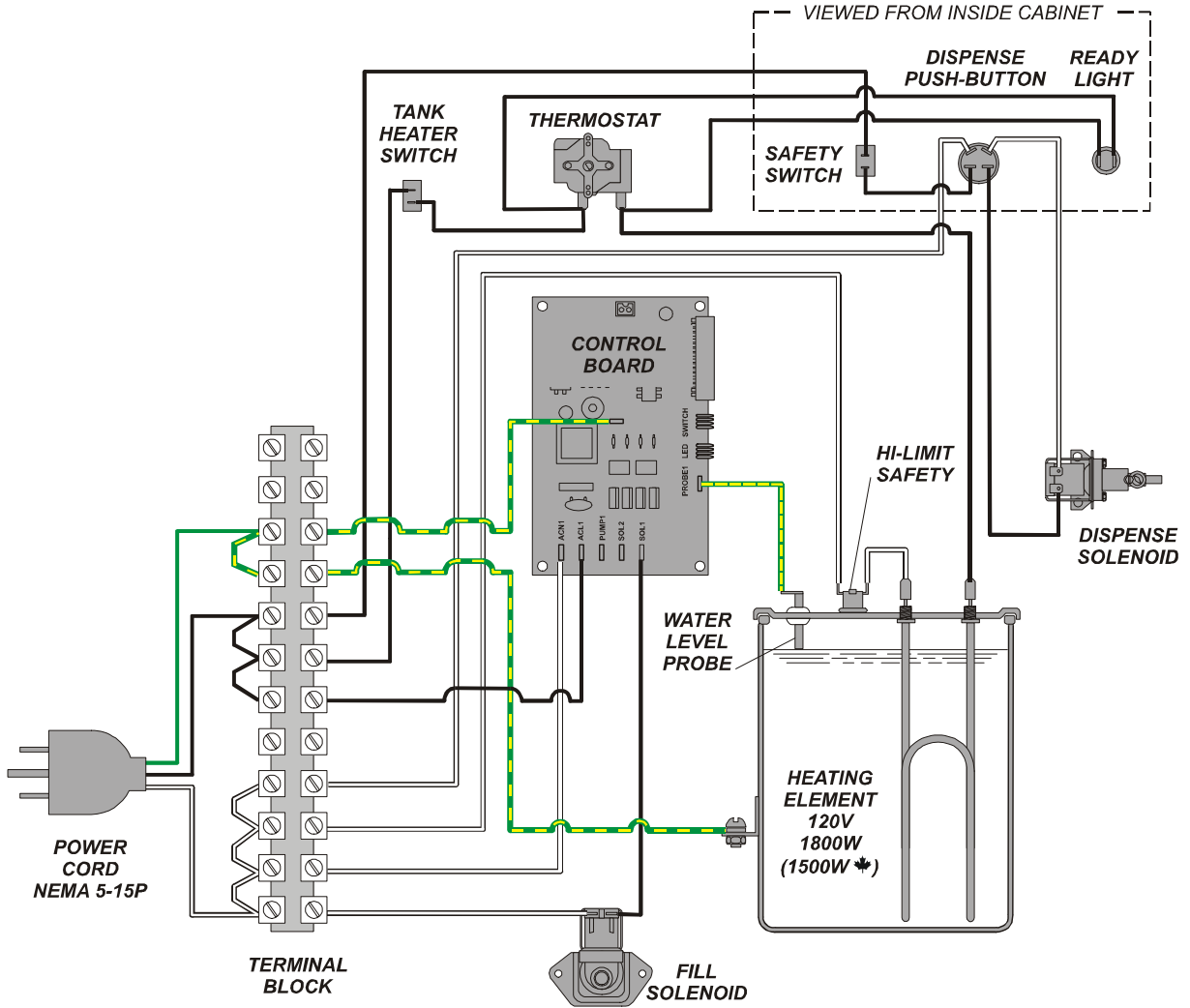

MODEL	VOLTS	Hz	WATTS	AMPS
0401	120	50/60	1800	15
* 0401CA	120	50/60	1500	12.5

EXPLODED VIEW & PARTS LIST

PLUMBING & RELATED COMPONENTS

MODELS: 0401

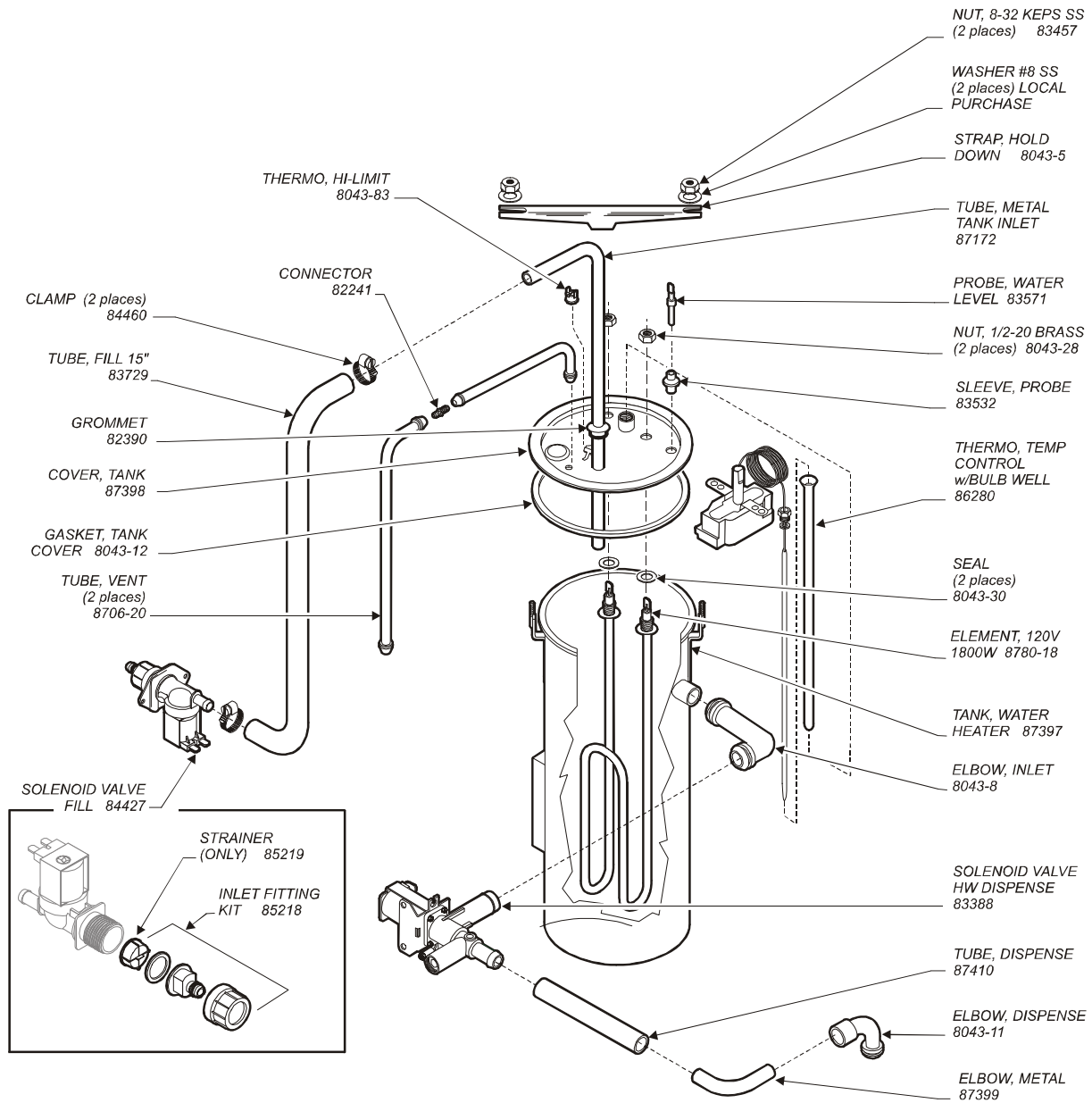

7145 77380 Owners Manual Horizon™ 0401 Hot Water Dispenser

EXPLODED VIEW & PARTS LIST (continued)

CABINET & CHASSIS ELECTRICAL COMPONENTS

MODEL: 0401

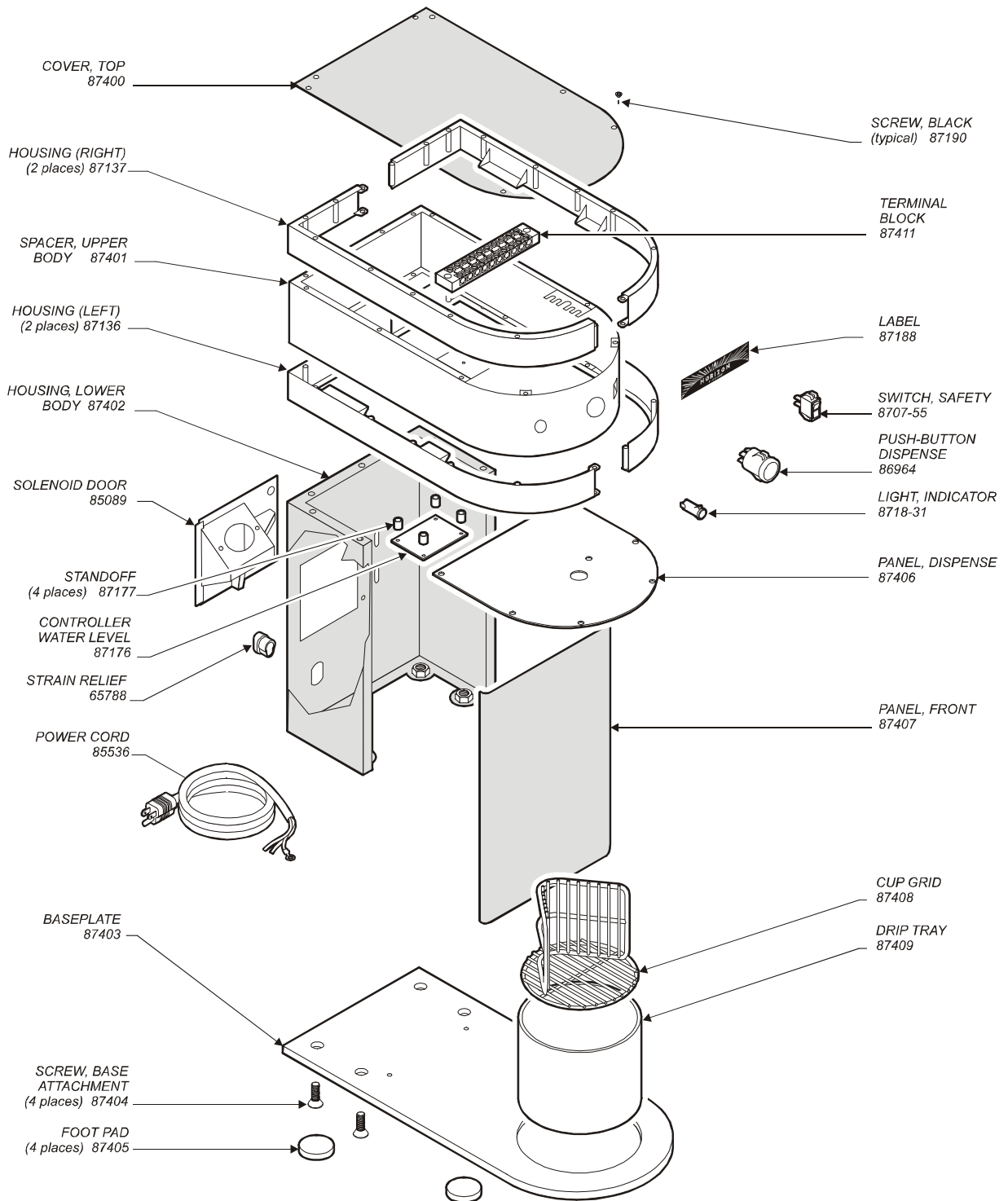

7145 77380 Owners Manual Horizon™ 0401 Hot Water Dispenser

CFESA

Commercial Food Equipment Service Association

Bloomfield Industries proudly supports CFESA
Commercial Food Equipment Service Association

SERVICE TRAINING - QUALITY SERVICE



CUSTOMER SATISFACTION



BLOOMFIELD

Bloomfield Industries, Inc.
Division of Carrier Commercial Refrigeration

In US and Canada

Telephone: 775-689-5700

Fax: 888-492-2783

Fax: 800-356-5142 (*for orders only*)

website: www.wellsbloomfield.com

PRINTED IN CHINA