

**BLOOMFIELD INDUSTRIES**

2 ERIK CIRCLE, P. O. Box 280  
Verdi, NV 89439  
telephone: 775-689-5700  
fax: 888-492-2783  
[www.wellsbloomfield.com](http://www.wellsbloomfield.com)



*Model 1092 Brewer  
with optional  
7759 Airpots*

**OWNERS MANUAL  
for****E. B. C.™  
Electronic  
Brew  
Control™****DUAL  
AIRPOT AND THERMAL  
COFFEE BREWERS****MODELS**

1090 1091  
1092 1093

**Includes:**

**Installation  
Use & Care  
Servicing Instructions**

E.B.C.™ brewers are protected under  
U. S. Patent # 5, 704,275  
Other U. S. and Canadian patents pending.

PRINTED IN UNITED STATES OF AMERICA

## WARRANTY STATEMENT

All electrical equipment manufactured by BLOOMFIELD INDUSTRIES is warranted against defects in materials and workmanship for a period of one year from the date of original installation or eighteen (18) months from the date of shipment from our factory, whichever comes first, and is for the benefit of the original purchaser, except that:

- a. airpots carry a 30 day parts warranty only.
- b. dispensers; i.e., tea and coffee carry a 90 days parts warranty only, excludes decanters.

THE FOREGOING OBLIGATION IS EXPRESSLY GIVEN IN LIEU OF ANY OTHER WARRANTIES, EXPRESSED OR IMPLIED, INCLUDING ANY IMPLIED WARRANTY OF MERCHANTABILITY OR FITNESS FOR A PARTICULAR PURPOSE, WHICH ARE HEREBY EXCLUDED.

BLOOMFIELD INDUSTRIES DIVISION / SPECIALTY EQUIPMENT MANUFACTURING CORPORATION SHALL NOT BE LIABLE FOR INDIRECT, INCIDENTAL OR CONSEQUENTIAL DAMAGES OR LOSSES FROM ANY CAUSE WHATSOEVER.

This warranty is void if it is determined that upon inspection by an Authorized Service Agency that the equipment has been modified, misused, misapplied, improperly installed, or damaged in transit or by fire, flood or act of God.

It also does not apply if the serial nameplate has been removed or unauthorized service personnel perform service. The prices charged by Bloomfield Industries for its products are based upon the limitations in this warranty. Seller's obligation under this warranty is limited to the repair of defects without charge by a Bloomfield Industries Authorized Service Agency or one of its sub-agencies. This service will be provided on customer's premises for non-portable models. Portable models (a device with a cord and plug) must be taken or shipped to the closest Authorized Service Agency, transportation charges prepaid, for services.

In addition to restrictions contained in this warranty, specific limitations are shown below (Additional Warranty Exclusions). Bloomfield Industries Authorized Service Agencies are located in principal cities.

This warranty is valid in the United States and void elsewhere. Please consult your classified telephone directory or your food service equipment dealer; or, for information and other details concerning warranty, write to:

**Service Parts Department  
Bloomfield Industries  
P.O. Box 280  
Verdi, NV 89439**

**Phone: (888) 492-2782**

**Fax: (888) 492-2783**

## SERVICE POLICY AND PROCEDURE GUIDE ADDITIONAL WARRANTY EXCLUSIONS

1. Resetting of safety thermostats, circuit breakers, overload protectors, or fuse replacements unless warranted conditions are the cause.
2. All problems due to operation at voltages other than specified on equipment nameplates; conversion to correct voltage must be the customer's responsibility.
3. All problems due to electrical connections not made in accordance with electrical code requirements and wiring diagrams supplied with the equipment.
4. Replacement of items subject to normal wear, to include such items as knobs and light bulbs. Normal maintenance functions including adjustment of thermostats, microswitches, and replacement of fuses and indicating lights are not covered under warranty.
5. All problems due to inadequate water supply, such as fluctuating, or high or low water pressure.
6. All problems due to mineral/calcium deposits, or contamination from chlorides/chlorines. De-liming is considered a preventative maintenance function and is not covered by warranty.
7. Full use, care and maintenance instructions are supplied with each machine. Those miscellaneous adjustments noted are customer responsibility. Proper attention will prolong the life of the machine.
8. Travel mileage is limited to sixty (60) miles from an authorized Service Agency or one of its sub-agencies.
9. All labor shall be performed during normal working hours. Overtime premium shall be charged to the customer.
10. All genuine Bloomfield replacement parts are warranted for ninety (90) days from date of purchase on non-warranted equipment. **Any use of non-genuine Bloomfield parts completely voids any warranty.**
11. Installation, labor and job check-out are not considered warranty.
12. Charges incurred by delays, waiting time or operating restrictions that hinder the service technicians ability to perform services are not covered by warranty. This includes institutional and correctional facilities.

## SHIPPING DAMAGE CLAIMS PROCEDURE

**NOTE:** For your protection, please note that equipment in this shipment was carefully inspected and packaged by skilled personnel before leaving the factory. Upon acceptance of this shipment, the transportation company assumes full responsibility for its safe delivery.

### IF SHIPMENT ARRIVES DAMAGED:

1. **VISIBLE LOSS OR DAMAGE:** Be certain that any visible loss or damage is noted on the freight bill or express receipt, and that the note of loss or damage is signed by the delivery person.
2. **FILE CLAIM FOR DAMAGE IMMEDIATELY:** Regardless of the extent of the damage.

3. **CONCEALED LOSS OR DAMAGE:** if damage is unnoticed until the merchandise is unpacked, notify the transportation company or carrier immediately, and file "CONCEALED DAMAGE" claim with them. This must be done within fifteen (15) days from the date the delivery was made to you. Be sure to retain the container for inspection.

Bloomfield Industries cannot assume liability for damage or loss incurred in transit. We will, however, at your request, supply you with the necessary documents to support your claim.

## TABLE OF CONTENTS

WARRANTY STATEMENT	xi
SPECIFICATIONS	1
FEATURES & OPERATING CONTROLS	2
PRECAUTIONS & GENERAL INFORMATION	3
AGENCY LISTING INFORMATION	3
INSTALLATION INSTRUCTIONS	4
OPERATION	6
BREWING COFFEE	10
CLEANING INSTRUCTIONS	11
TROUBLESHOOTING SUGGESTIONS	12
Error Detection	13
SERVICING INSTRUCTIONS	14
Deliming Instructions	20
EXPLODED VIEWS & PARTS LISTS	22
WIRING DIAGRAMS	26

Thank You for purchasing this Bloomfield Industries appliance.

Proper installation, professional operation and consistent maintenance of this appliance will ensure that it gives you the very best performance and a long, economical service life.

This manual contains the information needed to properly install this appliance, and to use, care for and maintain or repair the appliance in a manner which will ensure its optimum performance.

## SPECIFICATIONS

MODEL	STYLE	VOLTS	AMPS WATTS	1ø	POWER SUPPLY
1090♣ 1090R	Thermal	120/240V	4000W	16.7A	3-Wire (L1, L2, Neut) plus ground  Cord NOT SUPPLIED
1091♣ 1091R	Thermal	115/230V	7000W	30.4A	
1092♣ 1092R 1092SS	Airpot	120/240V	4000W	16.7A	
1093♣ 1093N 1093R	Airpot	115/230V	7000W	30.4A	

♣ Meets Canadian Standards

## APPLICABILITY

This manual applies to the following Bloomfield Industries E. B. C. ® products:

1090	1090R	
1091	1091R	
1092	1092R	1092SS
1093	1093NF	1093R

# FEATURES AND OPERATING CONTROLS

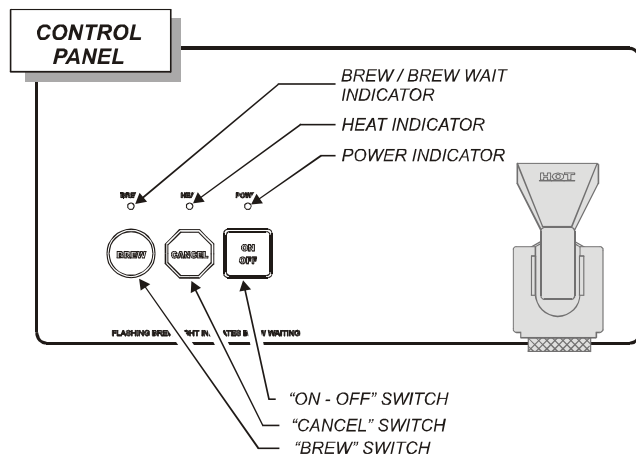
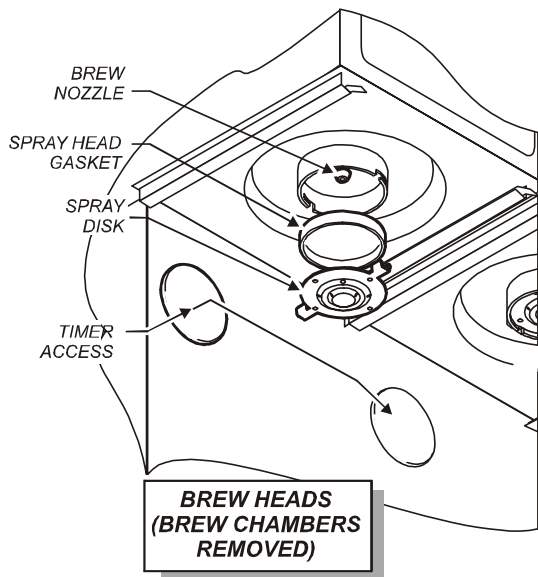
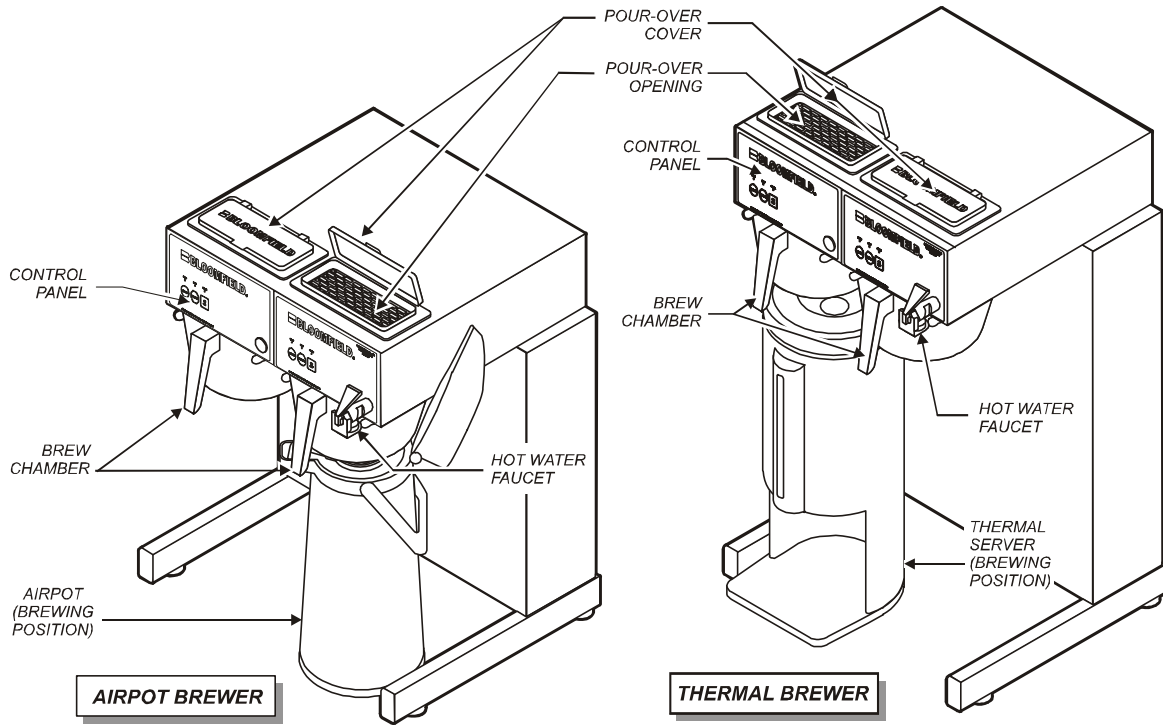

Fig. 1 Features & Operating Controls

## PRECAUTIONS AND GENERAL INFORMATION



**WARNING: Electric Shock Hazard**

All servicing requiring access to non-insulated components must be performed by qualified service personnel. Do not open any access panels which require the use of tools. Failure to heed this warning can result in electrical shock.



**WARNING: Injury Hazard**

All installation procedures must be performed by qualified personnel with full knowledge of all applicable electrical and plumbing codes. Failure could result in property damage and personal injury.



**WARNING Electric Shock Hazard**

Brewer must be properly grounded to prevent possible shock hazard. DO NOT assume a plumbing line will provide such a ground. Electrical shock will cause death or serious injury.



**WARNING: Burn Hazard**

This appliance dispenses very hot liquid. Serious bodily injury from scalding can occur from contact with dispensed liquids.

This appliance is intended for commercial use only.

This appliance is intended for use to brew beverage products for human consumption. No other use is recommended or authorized by the manufacturer or its agents.

This appliance is intended for use in commercial establishments, where all operators are familiar with the appliance use, limitations and associated hazards. Operating instructions and warnings must be read and understood by all operators and users.

Except as noted, this piece of equipment is made in the USA and has American sizes on hardware. All metric conversions are approximate and can vary in size.

The following trouble shooting, component views and parts lists are included for general reference, and are intended for use by qualified service personnel.

This manual should be considered a permanent part of this appliance. The manual must remain with the appliance if it is sold or moved to another location.



**CAUTION: Equipment Electrical Damage**

DO NOT plug in or energize this appliance until all *Installation Instructions* are read and followed. Damage to the Brewer will occur if these instructions are not followed.



**CAUTION: Burn Hazard**

Exposed surfaces of the appliance, brew chamber and Airpot or Server may be HOT to the touch, and can cause serious burns.

## AGENCY LISTING INFORMATION

This brewer is  and  listed under UL file E9253.

This brewer meets  Standard 4 only when installed, operated and maintained in accordance with the enclosed instructions.



## INSTALLATION INSTRUCTIONS

### READ THIS CAREFULLY BEFORE STARTING THE INSTALLATION

#### IMPORTANT:

To enable the installer to make a quality installation and to minimize installation time, the following suggestions and tests should be done before the actual unit installation is started:



#### CAUTION: Equipment Electrical Damage

DO NOT plug in or energize this appliance until all Installation Instructions are read and followed. Damage to the Brewer will occur if these instructions are not followed.



#### CAUTION: Unstable Equipment Hazard

It is very important for safety and for proper operation that the brewer is level and stable when standing in its final operating position. Provided adjustable, non-skid legs must be installed at each corner of the unit. Failure to do so will result in movement of the brewer which can cause personal injury and/or damage to brewer.

**NOTE:** Water supply inlet line must meet certain minimum criteria to insure successful operation of the brewer. Bloomfield recommends 1/4" copper tubing for installation of less than 25 feet and 3/8" for more than 25 feet from a 1/2" water supply line.

Unpack the unit. Inspect all components for completeness and condition. Ensure that all packing materials have been removed from the unit.

Verify that the Spray Head Gasket and Spray Disk are properly installed.

#### LEVELING THE UNIT

Verify that an adjustable leg is installed at each corner of the brewer, and that a rubber foot is installed on each leg.

Set Brewer in its operating location. Level the Brewer. A spirit level should be placed on the top of the unit, at the edge, as a guide when making level adjustments.

Level the unit from left to right and front to back by turning the adjustable feet. Be sure all four feet touch the counter to prevent tipping.

#### PLUMBER'S INSTALLATION INSTRUCTIONS

Brewer should be connected to a **POTABLE WATER, COLD WATER** line. Flush water line before connecting to Brewer.

DO NOT use a saddle valve with a self-piercing tap for the water line connection. Such a tap can become restricted by waterline debris. For systems that must use a saddle tap, shut off the main water supply and drill a 3/16" (minimum) tap for the saddle connection, in order to insure an ample water supply. Remember to flush the line prior to installing the saddle.

The brewer must be installed on a water line with average pressure between 20 PSI and 90 PSI. If your water pressure exceeds 90 PSI at anytime, a pressure regulator must be installed in the water supply line to limit the pressure to not more than 90 PSI in order to avoid damage to lines and solenoid.

Plumber must provide two 1/4" female flare water supplies for this brewer.

A water shut-off valve should be installed on the incoming water line in a convenient location (Use a low restriction type valve, such as a 1/4-turn ball valve, to avoid loss of water flow thru the valve.

## INSTALLATION INSTRUCTIONS (continued)

NSF requires that the brewer be able to be moved for cleaning underneath. A flex line or loops of copper tubing will satisfy this requirement. See Figure 2 below.

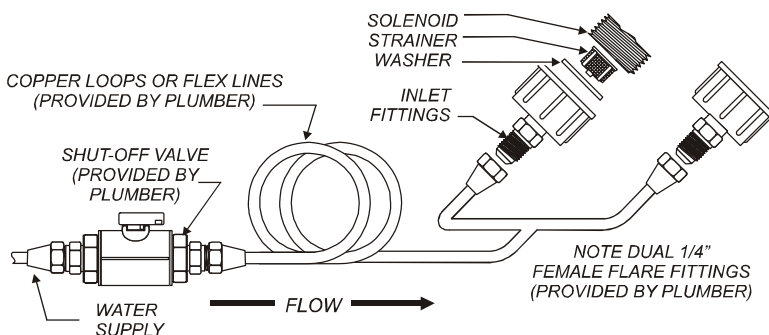

Fig. 2 Water Supply Installation

In some areas, local codes require a backflow preventer (check valve) to be installed on the inlet water line. If a backflow preventer is used, you must install a water hammer arrester in the incoming line, between the backflow preventer and the brewer inlet, as far away from the brewer as space will allow. This will relieve the excessive back pressures that can cause faucet leaks and solenoid malfunctions.

### ELECTRICIAN'S INSTALLATION INSTRUCTIONS

*REFER TO ELECTRICAL SPECIFICATIONS - Page 1*  
Check the nameplate to determine correct electrical service required for the Brewer to be installed.

**IMPORTANT:** Before connecting to electricity, make sure automatic brewers are connected to the water supply.

**Brewers** must be wired by an electrician, and require a dedicated 115/230V or 120/240V 20A circuit (50/60 Hz, L1, L2, Neutral, plus ground). Remove front panel to gain access to terminal block. Green terminal must be connected to a suitable building ground. Circuit must be capable of 4000 Watts (model 1090 and 1092) or 7000 Watts (model 1091 and 1093). See figure 3 at right.

**IMPORTANT:** Wiring must be installed in approved solid or flexible conduit, and must be secured to the brewer with a strain relief (to be provided by the installer).

**NOTE:** This equipment must be installed to comply with applicable federal, state and local plumbing codes and ordinances.



### WARNING ELECTRIC SHOCK HAZARD:

Brewer must be properly grounded to prevent possible shock hazard. **DO NOT** assume a plumbing line will provide such a ground. Electrical shock will cause death or serious injury.

**IMPORTANT:** Do not connect brewer to electrical power until the tank is filled with water. Pour water into the pour-over opening until water flows from the brew head.

**IMPORTANT:** Supply power must match nameplate for voltage and phase. Connecting to the wrong voltage will damage the brewer or result in decreased performance. Such damage is not covered by warranty.

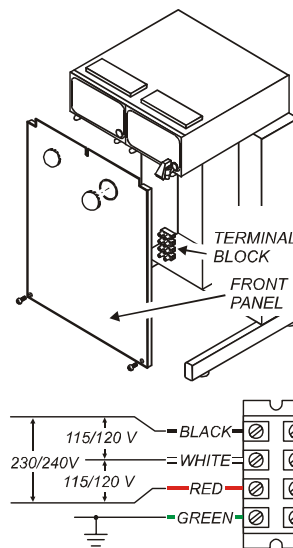

Fig. 3 115/240V Terminal Block

## OPERATION

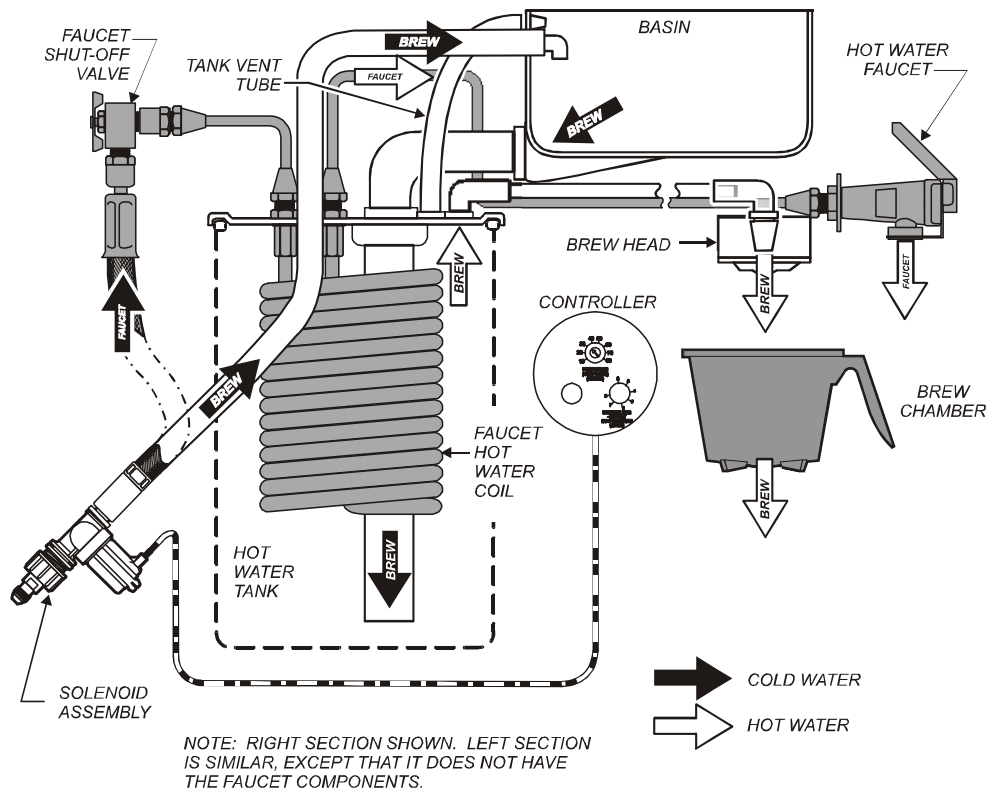

Fig. 4 Brewer Operation Diagram

### IMPORTANT:

Tank must be full of water before connecting brewer to electrical power. Heating elements will be damaged if allowed to operate without being fully submerged in water. Damage caused by operating the brewer without water in the tank is **NOT COVERED BY WARRANTY**.

### A. START-UP

For initial start-up, or if the brewer has not been used for an extended period of time:

- ◆ Be sure spray disk and brew gasket are properly installed in the brew head.
- ◆ Be sure the water supply is properly connected and the water supply valve is turned **ON**.
- ◆ Be sure the **WATER TANK IS FILLED**

*BEFORE* plugging the brewer into a receptacle, or otherwise connecting brewer to electrical power **THE WATER TANKS MUST BE FILLED**. Place an empty decanter under each brew head. Lift the pour-over cover then pour tap water into each pour-over opening until water flows from the brew heads. This will require the equivalent of three full 64oz. Decanters per side. When water stops dripping from the brew head, empty the container.

Once the tanks are full of water, connect the brewer to electrical power. For Models 1091 & 1093, press power switch to **ON**. The heating elements will begin heating the water in the tank. When the water has reached the proper temperature, the "READY TO BREW" LED will glow.

**WATER HEATER**

Water temperature is sensed by an electronic water temperature probe inserted into the water tank. This temperature signal is fed to the controller.

The setpoint temperature is adjustable. The controller sends a command signal to the power board based upon a comparison between the setpoint temperature and actual temperature. See page 15.

The power board energizes the heating elements based on the command signal from the controller.

Excessive temperature will trip the hi-limit safety switch. The hi-limit will automatically reset when the brewer cools.

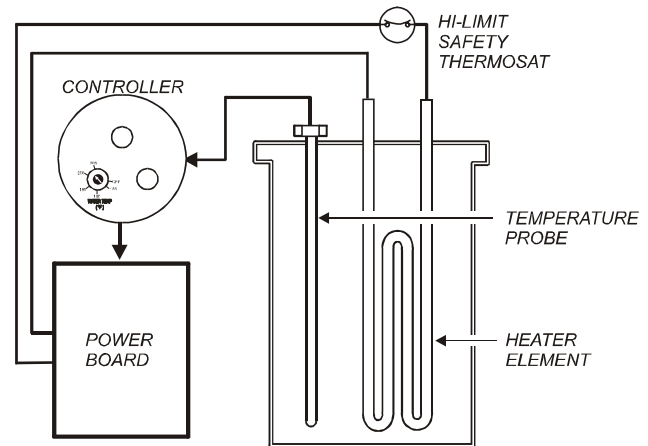

Fig. 5 Heat Control Diagram

**WATER FLOW**

**POUR-OVER FEATURE**

Pouring any amount of water into the pour-over opening and into the basin pan forces an identical amount of heated water out of the tank and through the spray head.

**AUTOMATIC OPERATION**

Pressing the BREW key energizes the solenoid valve, allowing water from an external water supply to flow into the water tank. The incoming water forces heated water out of the tank to perform the brew.

The solenoid uses a flow control device so that flow is consistent between 20 p.s.i. and 90 p.s.i.

The length of time the solenoid is open is controlled by the time setting of the controller. See page 18.

After the solenoid closes, water will continue to flow to the brew chamber until the water level in the tank falls below the brew pickup, breaking the siphon.

**HOT WATER FAUCET**

The faucet water coil is submerged in the hot water tank and draws heat from the brew water. Water going to the water coil is not controlled by the solenoid valve.

Hot water is provided at the faucet, at supply water pressure, any time the faucet shut-off valve is OPEN.

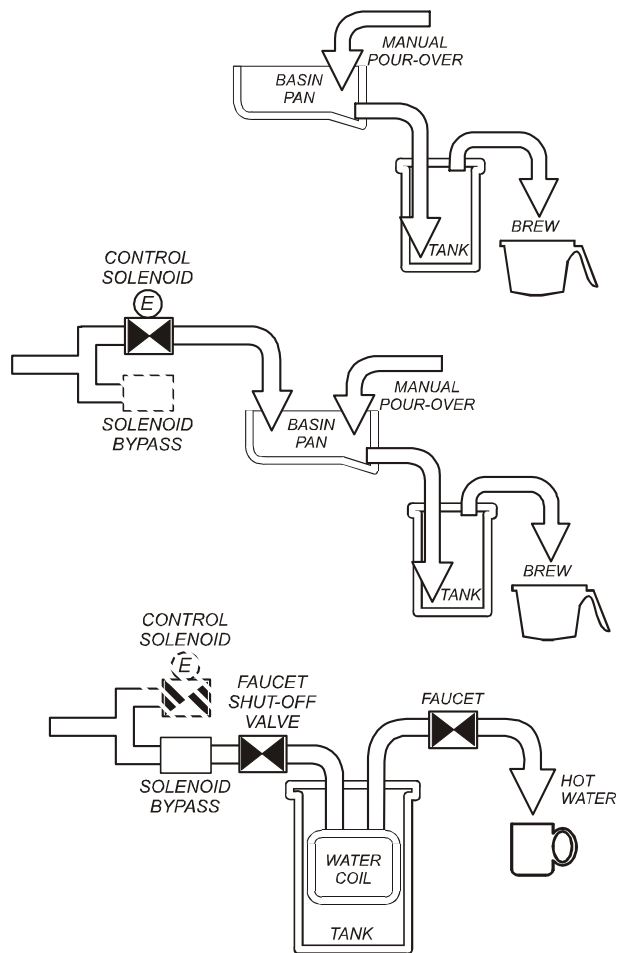

Fig. 6 Water Flow Diagram

## OPERATION (continued)

### IMPORTANT:

DO NOT energize this brewer until the water tank has been filled. Dry firing will damage heating elements. See page 6.

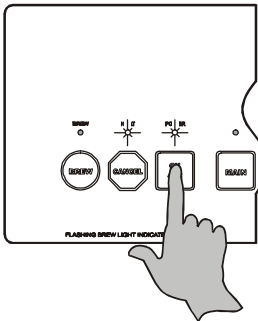

Fig. 7 Turning Brewer ON or OFF

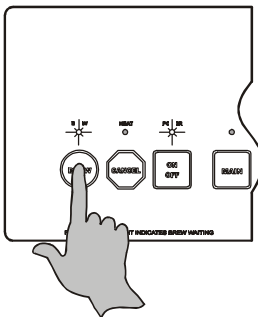

Fig. 8 Initiate a Brew

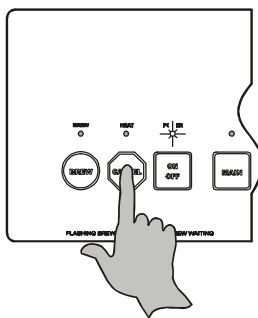

Fig. 9 Brew Cancel

## ELECTRONIC FEATURES

### Energizing the Brewer

When electric power is applied to the unit, all the lights will flash four times and four beeps will sound. The unit will be **OFF**.

Press the ON/OFF key. Four beeps will sound and all lights will flash once. The POWER indicator will remain **ON**. If the water temperature is more than 10°F below the setpoint, the HEAT indicator will glow until water temperature reaches setpoint.

Press the ON/OFF key again to turn the brewer **OFF**. Three beeps will sound, the tank heater and all warmers will be switched off, and all indicator lights will go out.

### Brew Settings

See pages 15 & 16 for setting Brew Time and Temperature.

### ABS™ (Automatic Brew Start)

Start a brew by pressing BREW. A single beep will sound. The system will verify that the water in the tank is at the proper temperature. If it is, brew will start immediately. Otherwise, the BREW indicator will flash (Brew Waiting Mode) until the water reaches setpoint temperature, then the indicator will glow and brew will commence. If the main warmer is off, it will be energized automatically.

At the conclusion of the brew cycle, three beeps will sound.

**NOTE:** To override Brew Waiting Mode, press and hold the BREW key for 3 seconds while the BREW indicator is flashing. Brew will begin regardless of water temperature. To avoid under-temperature brews, this feature should only be used when setting brew volumes.

**NOTE:** Brew Waiting Mode (BREW indicator flashing) prevents multiple, unattended brews. While the BREW indicator is on or flashing, any additional strokes of the BREW key will be ignored (there will be a beep each time the key is pressed, however). Another brew cannot be initiated until the previous brew is complete.

The Brew Waiting Time, also called Dripout Time, (interval between when the brew is initiated and the audible signal sounds at the end of the brew) may be adjusted between 2 and 8 minutes at the Brew Signal Timer dial on the controller. See page 16.

### Brew Cancel

To cancel a brew in progress or a brew in waiting, press the CANCEL key. Two beeps will sound and the BREW indicator will go out.

**NOTE:** If a brew in progress is cancelled, coffee will continue to flow until all water delivered has dripped through the brew chamber.

### Quality Timer

Coffee loses freshness as it sits on a warmer. The Quality Timer flashes the warmer lights 30 minutes after the last brew to remind you that the coffee is nearing the end of its useful life.

Quality Timer is normally set for 30 minutes. It can be set for 20 minutes by moving a jumper on the controller. See page 19.

### After Hours™ Operation

During normal operation, the controller will maintain the precise brewing temperature. If, however, if the BREW key is not pressed for 3 hours, the brewer goes into After Hours™ mode; any warmer left on will be turned off; and, the temperature will only be maintained to within 20°F. This feature prolongs component life and saves energy.

After Hours™ is an energy saving feature. The brewer will enter After Hours™ mode if it is not used for three hours. Press the BREW key to immediately return the brewer to normal operation.

As soon as the BREW key is pressed, the brewer returns to normal operation, heating the water to the precise temperature before beginning the brew. The brewer will return to After Hours™ mode only if three hours pass without a brew being initiated.

### Disable/Enable After Hours™ Feature

To disable After Hours™, press the ON/OFF key to turn the brewer **OFF**. Press and hold the CANCEL key until two beeps sound, and the HEAT indicator flashes twice. This feature is now disabled.

To re-enable After Hours™, press the ON/OFF key to turn the brewer **OFF**. Press and hold the CANCEL key until three beeps sound, and the POWER indicator flashes twice. This feature is now enabled, however, it will not be activated unless no brew is initiated for three hours.

### Over-Temperature and Temperature Fault Protection

Should the water temperature exceed 214°F (101°C), or if the controller does not detect a 2°F (1°C) rise in temperature within four minutes of calling for heat, the brewer will go into Over Temperature Mode; the heating element is turned off, all warmers are disabled and all lights will flash.

**IMPORTANT:**  
If the original cause of the problem has not been addressed, the brewer will once again go into Over Temperature mode four minutes after being reset.

Possible causes of Over Temperature condition:

- Setpoint is in the boiling range.
- Heating element or temperature probe has malfunctioned.
- Excessive scale buildup is preventing the element from heating the water.
- Heating element relay fails in the "on" state.
- No water in the tank.
- Hi-limit safety tripped (must be manually reset)

To reset the brewer:

- Determine the cause of the failure and take appropriate remedial action to rectify the problem.
- Press and hold the CANCEL key for three seconds. Four beeps will sound and the brewer will resume normal operation.

## BREWING COFFEE



### CAUTION: Burn Hazard

Exposed surfaces of the brewer, brew chamber and airpot or server may be **HOT** to the touch, and can cause serious burns.



### CAUTION: Burn Hazard

To avoid splashing or overflowing hot liquids, **ALWAYS** place an empty airpot or server under the brew chamber before starting the brew cycle. Failure to comply can cause serious burns.



### CAUTION: Burn Hazard

After a brew cycle, brew chamber contents are **HOT**. Remove the brew chamber and dispose of used grounds with care. Failure to comply can cause serious burns.

**NOTE:** The brewer will not initiate a second automatic brew cycle until the current cycle plus the drip-out time is completed. The "BREW" light will flash indicating a brew in progress.

**NOTE:** Water for the hot water faucet is heated in a coil inside of the water tank. Use of the faucet will not affect the volume of water delivered for a brew. However, overuse of the faucet during a brew may lower the temperature of the brew water.

### B. PREPARATION

Place one (1) genuine Bloomfield paper filter in the brew chamber.

Add a pre-measured amount of fresh coffee grounds.

Gently shake the brew chamber to level the bed of grounds. Slide the brew chamber into place under the brew head.

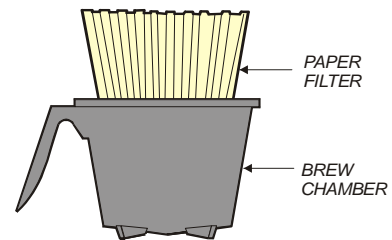

Fig. 10 Brew Chamber

### C. POUR-OVER OPERATION

**NOTE:** Any E..B.C™ brewer can be used in the pour-over mode.

BE sure "HEAT" light is not lit.

Place the appropriate *EMPTY* airpot or thermal server in place under the brew chamber.

Fill an airpot or server, *identical to the one being used*, with tap water. Lift the pour-over cover and pour the entire contents of the container into the pour-over opening, which will fill the basin.

Water from the basin will displace a like amount of heated water from the tank. The hot water will be forced into the brew head where it will spray over the bed of grounds. Freshly brewed coffee will begin to fill the container under the brew chamber. When the flow and all dripping stops, the coffee is ready to serve.

Discard the contents of the brew chamber. Rinse the brew chamber in a sink. When the "HEAT" light goes out, the brewer is ready for another brew cycle.

### C. AUTOMATIC OPERATION

BE sure "HEAT" light is not lit.

Place the appropriate *EMPTY* airpot or thermal server in place under the brew chamber.

Press the "BREW" switch. The "BREW" light will glow and a beep will sound. The solenoid will open for an amount of time determined by the timer setting, admitting a measured quantity of water into the basin.

Water from the basin will displace a like amount of heated water from the tank. The hot water will be forced into the brew head where it will spray over the bed of grounds. Freshly brewed coffee will begin to fill the container under the brew chamber. At the end of the brew cycle, plus an amount of time set to allow all water to drip out of the brew chamber, two beeps will sound. When the flow and all dripping stops, the coffee is ready to serve.

Discard the contents of the brew chamber and rinse it in a sink. When the "READY TO BREW" light glows, the brewer is ready for another brew cycle.

## CLEANING INSTRUCTIONS

### PROCEDURE: Clean Coffee Brewer

**PRECAUTIONS:** Disconnect brewer from electric power.  
Allow brewer to cool.

**FREQUENCY:** Daily

**TOOLS:** Mild Detergent, Clean Soft Cloth or Sponge  
Bristle Brush.

1. Disconnect brewer from electric power.  
Allow brewer to cool before cleaning.
2. Remove and empty airpots or thermal servers.
3. Remove and empty brew chambers.
4. Remove spray disks from the brew heads (See figure 8):  
Press up on the spray disk ears, then turn the disk to the left to unlatch. Remove gaskets from inside the brew heads.
5. Wipe inside of brew heads and area around the brew heads with a soft clean cloth or sponge moistened with clean water.
6. Wash the spray disks in a sink using warm water and a mild detergent. A bristle brush may be used to clear clogged spray holes. Rinse the spray disks with clean water and allow to air dry.
7. Wash the brew chambers in a sink using warm water and a mild detergent. A bristle brush may be used to clean the inside. Rinse with clean water and allow to air dry. For stainless steel brew chambers, be sure the wire rack is properly reinstalled.
8. Wipe the exterior of the brewer with a soft clean cloth or sponge moistened with clean water.
10. Reinstall the gaskets *INSIDE* the brew heads, then reinstall the spray disks.
11. Reinstall the brew chambers.
12. DO NOT submerge airpots or thermal servers in water. Clean airpots and thermal servers by filling with warm soapy water. Scrub the inside with a bottle brush. Empty and rinse with clean water. Wipe the exterior with a soft clean cloth or sponge moistened with clean water. Invert and allow to air dry.

Procedure is complete



**CAUTION:**  
Burn Hazard

Brewing and serving temperatures of coffee are extremely hot. Hot coffee will cause serious skin burns.



**CAUTION:**  
Electric Shock Hazard

Do not submerge or immerse brewer in water.

### IMPORTANT:

DO NOT use steel wool, sharp objects, or caustic, abrasive or chlorinated cleansers to clean the brewer.

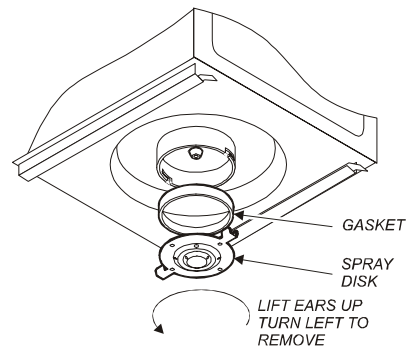

Fig. 11 Cleaning

## TROUBLESHOOTING SUGGESTIONS

SYMPTOM	POSSIBLE CAUSE	SUGGESTED REMEDY
Water won't heat	Brewer unplugged or circuit breaker tripped	Check power supply cord Check / reset circuit breaker
	Temperature adjusted too low or set to <i>OFF</i>	Turn on and set for desired temperature. See page 15
	Hi-Limit thermostat tripped	Allow to cool. Reset hi-limit
	Damaged internal component or wiring	Examine wiring & connectors, controller, power board and heating element Repair/replace as needed
Coffee level too high or low	Timer out of adjustment	Adjust controller. See page 16
Brew chamber overflows	Too many filter papers or wrong filter paper	Use one (1) genuine Bloomfield filter per brew
	Brew chamber dispense hole plugged	Thoroughly clean brew chamber
Sprays water from brew head	Spray gasket improperly installed	Check/reinstall gasket on <b>INSIDE</b> of brew head
No brew while faucet flows OK	Spray disk plugged	Clean spray disk
	Damaged internal component or wiring	Check keypad, controller, power board & solenoid Repair, replace as needed
No brew plus no flow from hot water faucet	Water supply OFF	Turn water supply ON
	Solenoid screen plugged	Clean solenoid screen
	Water line strainer (if used) plugged	Clean strainer
No flow from hot water faucet	Water filter (if used) plugged	Replace filter element
	Faucet valve turned OFF	Turn faucet valve ON
	Faucet plugged	Disassemble faucet, clean
Poor coffee quality	Keep brewer and decanters clean. Install a taste and odor filter in water supply, and replace cartridges regularly. Use a quality coffee with a consistent roast. Use proper grind and amount of coffee per brew.	

## ERROR DETECTION

This brewer is designed to perform a continuous internal diagnosis, and to signal faults by flashing all the lights. In fault mode, warmers, heating element and water fill solenoid are turned “off”, and most keypad functions are disabled.



**CAUTION  
ELECTRIC SHOCK  
HAZARD**

Error detection (all lights flashing) will occur under two conditions:

- Anytime a temperature in excess of 214°F is detected.
- Temperature does not change by at least 2°F within 4 minutes of tank heater being energized (HEAT light on).

Live electrical circuits may be exposed while performing these procedures. These procedures are to be performed by qualified technical personnel only.

To reset the brewer after the fault has been corrected, press and hold the CANCEL key for 3 seconds, or disconnect the brewer from electrical power for three seconds.

WHAT TO CHECK	DESCRIPTION	CORRECTIVE ACTION
Has the water tank been properly filled?	On initial startup, an attempt to heat a dry tank will be detected as too high a temperature or insufficient temp rise, or will trip the high limit.	Tank must be properly filled as detailed on page 6. Check hi-limit (see below)
Has hi-limit safety thermostat tripped off?	Brewer may have been started without water in the tank, or the temp control thermostat may require adjustment.	Access hi-limit by removing front panel. Hi-limit is on the left side of the tank. Use an insulated tool to push the red button in until it “clicks” and stays. Reset per above.
Check control board and temp probe.	Brewer will go into error mode immediately if either the control board or temp probe is defective. Temp probe electrical resistance is approximately 30KΩ at room temp, and 2KΩ at boiling. Replace temp probe if less than 1KΩ.	Reset by holding the CANCEL key for 3 seconds. If lights continue to flash: Disconnect temp probe from control board. a. If lights continue to flash, unplug brewer and replace control board. b. If lights stop flashing, unplug brewer and replace temp probe.
Check power board and heating element.	Brewer will go into error mode 4 minutes after energizing the heating element if insufficient heat rise is detected. The heating element is energized by an electronic power board, and protected by the hi-limit safety. Heating element should receive full line voltage (i.e. 120V, 208V or 240V). Be sure the hi-limit safety is reset.	Reset by holding the CANCEL key for 3 seconds. If lights resume flashing after 4 minutes: Check the voltage across the heating element terminals: a. If no voltage is present, unplug brewer and replace power board. b. If proper voltage is present, unplug brewer and replace tank heating element.
Is the brew temperature properly adjusted?	The brewer may occasionally go into error mode if the brew temperature is set too high.	See page 15 for temperature adjustment procedure.

## SERVICING INSTRUCTIONS



**CAUTION**  
Electric Shock  
Hazard

Opening access panels or removing warmer plates on this brew may expose uninsulated electrical components. Disconnect brewer from electrical power before removing any panel or warmer plate.

### ACCESS PANELS

#### TOP PANEL:

Remove top panel to access hot water tank, thermo probe, heating elements, brew circuit tubing, faucet valve and piping.

Top panel is held by two screws at the rear and a retaining lip at the front.

#### FRONT PANEL:

Remove front panel to access controller, terminal block and solenoid.

Front panel is held by two screws at the bottom and a retaining lip at the top.

#### SOLENOID DOOR:

Remove solenoid door to access solenoid plumbing connections.

Solenoid door is held by two screws and a retaining lip.

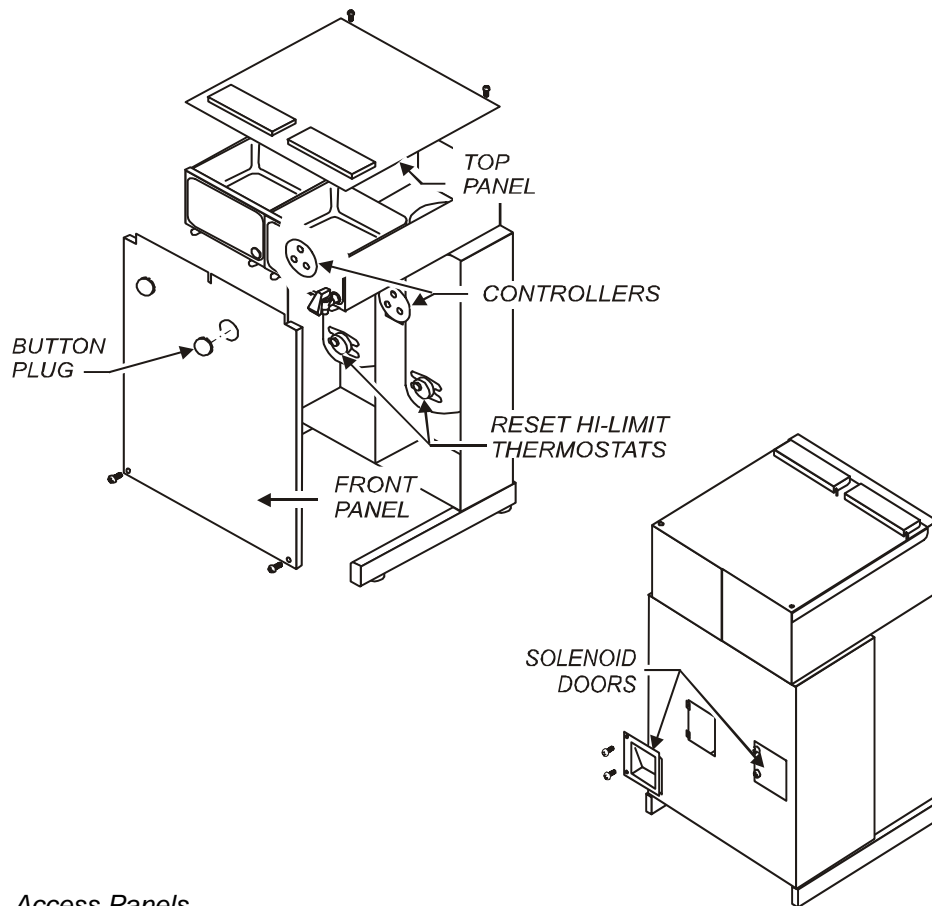

Fig. 12 Access Panels

## SERVICING INSTRUCTIONS (continued)

### TEMPERATURE ADJUSTMENT

Unplug power cord or turn circuit breaker OFF. Remove top panel. Remove button plug from front panel.



**CAUTION**  
Electric Shock  
Hazard

These procedures involve exposed electrical circuits. These procedures are to be performed by qualified technical personnel only.

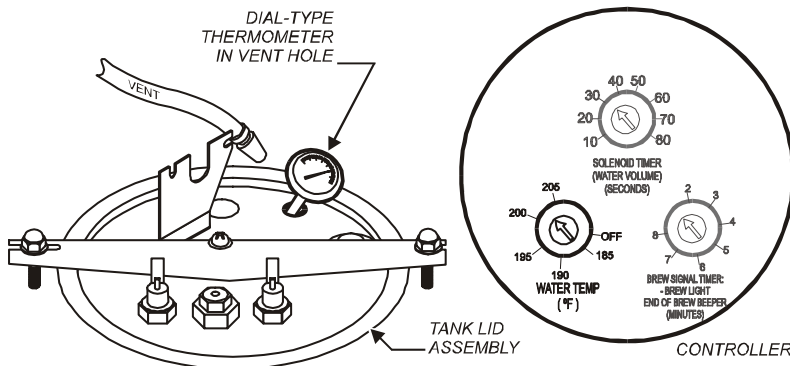

Fig. 13 Checking and Adjusting Brew Temperature

Pull vent tube out of tank lid and insert a thermometer of known accuracy in vent hole. Reconnect brewer to electrical power. Place empty container under brew chamber. Energize brewer and pour one decanter (64 oz.) of cold water into pour-over opening. When HEAT light goes out, read the temperature displayed on thermometer.

Adjust WATER TEMP dial on controller; clockwise increases temperature. Refer to Table 1 below for proper brewing temperature based on altitude.

**NOTE:** Optimum brewing temperature is 195°F to 205°F (90°C to 96°C). Maximum temperature setting should be no more than 205°F (96°C).

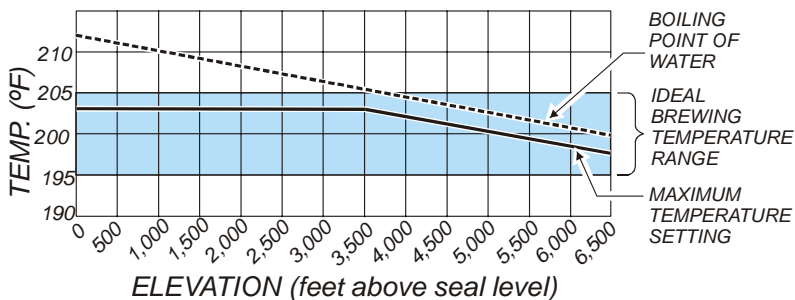

Table 1 Boiling Temperature by Altitude

**IMPORTANT:**  
An electronic temperature controller will maintain temperature within  $\pm 2^\circ\text{F}$ . To prevent boiling water in the brewer, controller should be adjusted to a maximum temperature equal to the local boiling temperature minus  $2^\circ\text{F}$ , or  $205^\circ\text{F}$ , whichever is less.

Upon completion, remove thermometer and reinstall vent tube.

## SERVICING INSTRUCTIONS (continued)

**IMPORTANT:** Water pressure must be between 20 p.s.i and 90 p.s.i. flowing pressure. If water pressure exceeds this value, or if water pressure varies greatly, a pressure regulator must be installed in the water supply line.

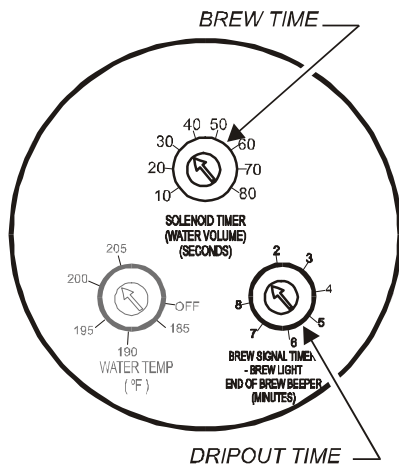

Fig. 14 Adjust Brew Time and Dripout Time

**IMPORTANT:** Before setting assembly into tank, make sure tank lid gasket is properly seated on flange of lid. **DO NOT OVER-TIGHTEN.**

**IMPORTANT:** When replacing temperature probe, be sure a new seal washer is in place around the probe. Tighten jamb lock nut only enough to ensure no water leakage. Excessive tightening is not necessary.

**IMPORTANT:** When replacing heating element, also replace seal gaskets.

### BREW TIME ADJUSTMENT

The amount of water dispensed automatically during a brew cycle is controlled by the SOLENOID TIME dial of the controller.

Place empty decanter under brew chamber. Press BREW button. Brewer should dispense one full decanter of water. To adjust amount:

Remove brew chamber and button plug. On the controller, adjust SOLENOID TIME dial (BREW TIME); clockwise increases time. Run several cycles to check amount of water delivered.

### DRIPOUT TIME ADJUSTMENT

Water delivered to the brew chamber will take a while to drip through as coffee. The time between the end of a brew and when a new brew can be initiated is controlled by the BREW SIGNAL TIMER. Adjust the BREW SIGNAL TIMER dial on the controller to account for the dripout time. Replace button plug.

### REMOVE TANK LID ASSEMBLY

Unplug brewer or turn circuit breaker *OFF*. Turn *OFF* water supply. Remove top panel. Pull vent tube and inlet elbow out of basin pan.

On automatic models, pull water inlet tube out of basin pan. Remove basin pan.

On models with faucet, disconnect inlet pipe at faucet shut-off valve and outlet pipe at faucet.

Disconnect all wiring from hi-limit and heating element. Disconnect temperature probe from controller.

Loosen center screw on tank hold-down bracket. Remove hold-down bracket by sliding short slotted end off of locking stud and lifting it off. Remove cover assembly by lifting it straight up.

Reassemble in reverse order.

### REPLACE TEMPERATURE PROBE

Unplug brewer or turn circuit breaker *OFF*. Remove top panel.

Loosen and free jam nut from pass-thru fitting securing temperature probe. Disconnect temperature probe wiring connector from controller. Lift out probe, jamb nut and gasket.

Reassemble in reverse order.

### REPLACE HEATING ELEMENT

Remove tank lid assembly per above.

Remove two hex nuts holding element to cover. Pull element from mounting holes.

Reassemble in reverse order.

## SERVICING INSTRUCTIONS (continued)

### REPLACE SOLENOID

Unplug power cord. Turn *OFF* and disconnect water supply from brewer inlet fitting.

Remove front panel. Remove two screws holding access door in place. Remove access door and solenoid. Unscrew inlet fitting cap to release solenoid from door.

Remove wiring from solenoid.

Large end of wrench 86660 can be used to hold solenoid inlet fitting while disconnecting supply line.

### REPLACE FAUCET SUPPLY HOSE

Unplug power cord. Turn *OFF* and disconnect water supply from brewer inlet fitting. Disconnect hose fitting from solenoid (See illustration at right).

Disconnect hose flare fitting from tank coil fitting.

### REPLACE HOT WATER FAUCET COIL

(Symptom: Brewer drips continuously from brew head, except when faucet valve is turned *OFF*.)

**IMPORTANT:** When replacing water faucet coil, also replace seal gaskets.

Remove tank lid assembly per above.

Remove two hex nuts hot water coil to cover. Pull coil from mounting holes.

### REPAIR HOT WATER FAUCET

Remove top panel and turn faucet valve *OFF*.

Unscrew aerator cap from faucet and remove handle retaining clip. Do not let faucet body turn.

Pull bonnet assembly from faucet body.

Examine the interior of the faucet body and the surface of the seat cup. Clean out any debris in the faucet body, using a stiff bristle brush if necessary.

**NOTE:** Any abrasion or roughness on the flat end of the seat cup will require replacing the seat cup:

Work the seat cup out of the bonnet and off of the end of the stem.

Install a new seat cup, making sure the knob on the stem is fully inserted into the pocket of the seat cup, and the skirt of the seat cup is fully inserted into the bonnet.

Examine the aerator. Clean any debris from the screen or flow straightener, using a stiff bristle brush if necessary.

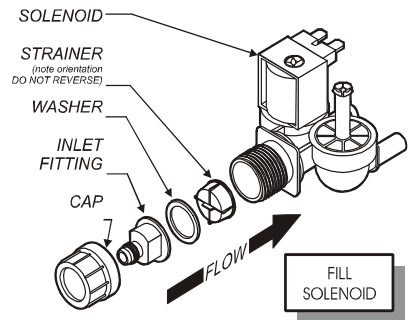
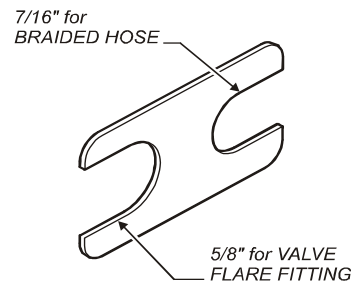
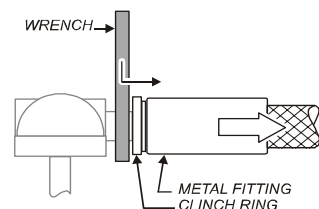
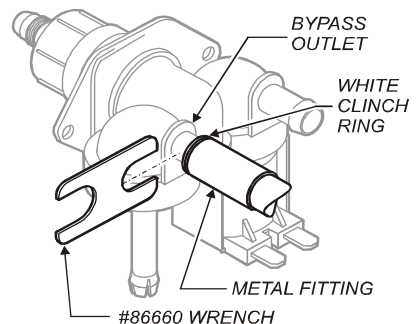

Fig. 15 Fill Solenoid



P/N 86660 Braided Hose Wrench



SLIDE WRENCH BETWEEN VALVE AND HOSE FITTING PRESS CLINCH RING TOWARD METAL FITTING TO RELEASE

Fig. 16 86660 Solenoid Wrench

## SERVICING INSTRUCTIONS (continued)

**IMPORTANT:** When replacing water faucet coil, also replace seal gaskets.

**NOTE:** Any abrasion or roughness on the flat end of the seat cup will require replacing the seat cup:

Work the seat cup out of the bonnet and off of the end of the stem.

Install a new seat cup, making sure the knob on the stem is fully inserted into the pocket of the seat cup, and the skirt of the seat cup is fully inserted into the bonnet.

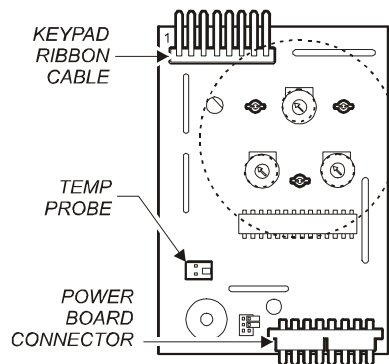

Fig. 17 Controller Hook-Up

### REPLACE HOT WATER FAUCET COIL

(Symptom: Brewer drips continuously from brew head, except when faucet valve is turned OFF.)

Remove tank lid assembly per above.

Remove two hex nuts hot water coil to cover. Pull coil from mounting holes.

Reassemble in reverse order.

### REPAIR HOT WATER FAUCET

Remove top panel and turn faucet valve OFF.

Unscrew aerator cap from faucet and remove handle retaining clip. Do not let faucet body turn.

Pull bonnet assembly from faucet body.

Examine the interior of the faucet body and the surface of the seat cup. Clean out any debris in the faucet body, using a stiff bristle brush if necessary.

Examine the aerator. Clean any debris from the screen or flow straightener, using a stiff bristle brush if necessary.

Reassemble in reverse order.

### RESET HI-LIMIT

Allow brewer to cool. Remove front panel.

Press red button on hi-limit until it clicks and stays in.

Reassemble in reverse order. Test for function and proper operation.

### REPLACE CONTROLLER

Unplug power cord or turn circuit breaker OFF.

Remove front panel. Remove timer faceplate. Use needle nose pliers to disengage three barbed fittings holding controller to bracket. Disconnect keypad ribbon cable (note position "1"), temperature probe and power board cable.

Set jumpers as described on page 19.

Reassemble in reverse order.

Adjust controller as described on pages 15 & 16.

## SERVICING INSTRUCTIONS (continued)

### SET CONTROLLER JUMPERS

Placing the jumper across Q1 sets Quality Time at 20 Minutes.

Placing the jumper across Q2 sets Quality Time at 30 Minutes.

Removing jumpers from both Q1 or Q2 disables Quality Timer.

Placing the jumper across V1 sets Valve Time Range to 60 - 180 seconds.

Removing jumper from V1 sets Valve Time Range to 10 - 80 seconds.

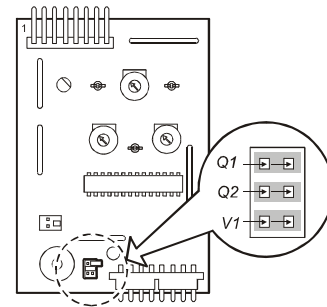

Fig. 18 Controller Jumpers

### REPLACE KEYPAD

Unplug power cord or turn circuit breaker OFF. Shut off water supply valve. Remove top and front panels.

Remove faucet from basin body.

Disconnect ribbon cable from controller. Pry faceplate/keypad from basin body. Remove all adhesive residue.

Remove protective backing from adhesive on new keypad.

**Note:** There is a clear protective wrap on the ribbon cable to provide abrasion resistance where the cable passes through the cabinet. Do NOT remove this protective sleeve.

Slide ribbon cable into slot on basin body from the outside, then carefully apply keypad to face of basin body.

Ribbon cable connects to P2 on controller. Note locator marking "1" on connector and cable.

Reassemble in reverse order. Test new keypad for function and proper operation.

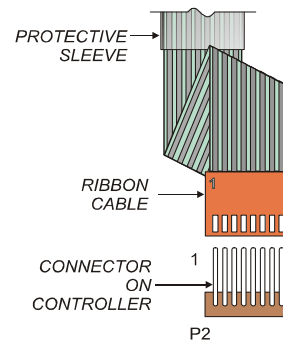

Fig. 19 Keypad Ribbon Cable Hook-Up

### REPLACE POWER BOARD

Unplug power cord or turn circuit breaker OFF. Shut off water supply valve. Remove front panel. Remove water tank lid (see page 16), then pull tank from cabinet.

Note position of wires at power board, then remove wires.

Suggestion: Marking these wires is highly recommended to ease reinstallation.

Remove screws holding power board to cabinet. Remove power board from cabinet.

Reassemble in reverse order. Test for function and proper operation.

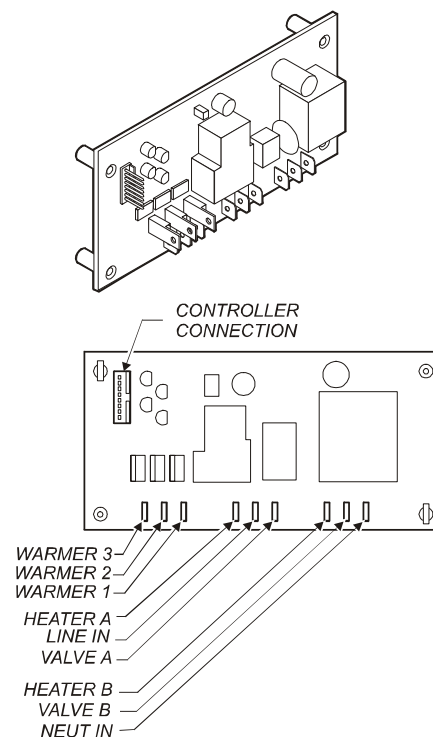

Fig. 20 Power Board Hook-Up

## SERVICING INSTRUCTIONS (continued)



### CAUTION - CHEMICAL BURN HAZARD

Deliming chemicals are caustic. Wear appropriate protective gloves and goggles during this procedure.

Never siphon deliming chemicals or solutions by mouth.

This operation should only be performed by qualified and experienced service personnel.

---

**IMPORTANT:** DO NOT spill, splash or pour water or deliming solution into or over any internal component other than the inside of the water tank.

---

**IMPORTANT:** DO NOT allow any internal components to come into contact with the deliming solution. Take care to keep all internal components dry.

**NOTE:** Repeat steps 4 thru 5 as required to remove all scale and lime build-up.

### PROCEDURE: Delime the Water Tank

**PRECAUTIONS:** Disconnect brewer from electric power. Allow brewer to cool.

**FREQUENCY:** As required (Brewer slow to heat)

**TOOLS:** Deliming Solution  
Protective Gloves, Goggles & Apron  
Mild Detergent, Clean Soft Cloth or Sponge  
Bristle Brush, Bottle Brush  
Large Sink (or other appropriate work area)

- 
1. Disconnect brewer from the electrical supply. Turn off the water shut-off valve and disconnect the water supply line from the brewer inlet fitting. On right side tank, disconnect faucet fittings.
  2. Remove the tank lid assemblies as described on page 16.
  3. Remove the water tanks from the brewer body by lifting straight up. Empty all water from the tanks. Set the tanks back into the brewer.
  4. For each tank, mix 2 quarts of deliming solution according to the manufacturer's directions. Carefully pour the deliming solution into the tanks. Lower the lid assemblies back onto the tank. Allow to sit for 30 minutes, or as directed by the manufacturer.
  5. At end of soaking period, remove lid assemblies from tanks. Thoroughly rinse internal components of lid assemblies with clear water. Using a stiff bristle brush, scrub the heating element (and for the right side, the faucet water coil) to remove lime and calcium build-up. Rinse with clean water. Store lid assemblies in a safe location .
  6. Remove the tanks from the brewer and empty. Using a stiff bristle brush, scrub the interior of the tanks to remove lime and calcium build-up. Rinse with clean water.

## SERVICING INSTRUCTIONS (continued)

7. Set the tanks back into the brewer. Reassemble the tank lid to the tanks. Make sure the gasket is properly in place, then reinstall the hold-down strap.
8. Reinstall wiring to heating elements and controller. Reinstall the hi-limit thermostat (if removed). For right side, reassemble piping for the faucet. Verify that all internal components are dry, then reinstall the top panel.
10. Reconnect brewer to electrical supply and reconnect water supply.
11. Install the brew chambers without filter papers or grounds. Run at least three full brew cycles and discard all water generated.
12. Brewer is ready to use.

**NOTE:** Normally, silicone hoses do not need to be delimed. Should deliming hoses become necessary, Bloomfield recommends replacing the hoses.

# EXPLODED VIEW & PARTS LIST

## HOT WATER TANK ASSEMBLY

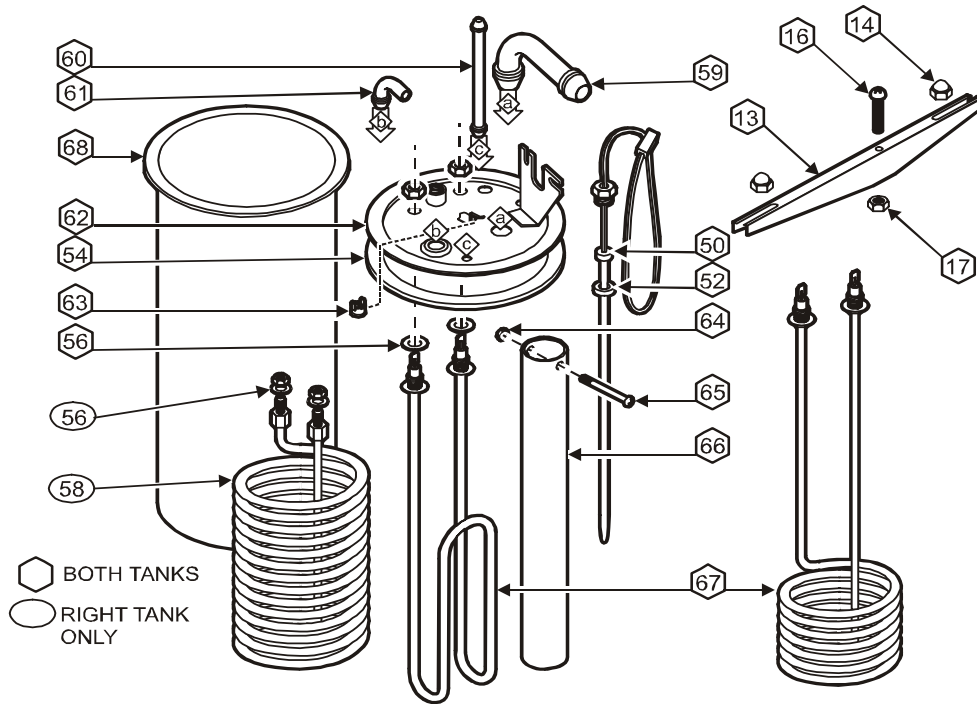

ITEM	PART NO.	DESCRIPTION	USED ON
13	8043-5	Hold Down Strap	All
14	8043-506	Nut, 8-32 SS Acorn	All
50	83644	Temperature Probe	All
52	83731	Seal Washer	All
54	8043-12	Tank Cover Gasket	All
56	8043-30	Seal Gasket	All
58	8540-6	Hot Water Coil	All - Right Tank Only
59	8043-8	Inlet Elbow	All
60	8043-15	Vent Tube	All
61	8043-11	Outlet Elbow	All
62	8514-68	Tank Cover (Plate Only, 8-holes)	All - Right Tank Only
	8512-45	Tank Cover (Plate Only, 6-holes)	All - Left Tank Only
64	8543-74	Nut, Hex 4-40 SS	All
65	8543-73	Screw 4-40 x 1 SS Pan Head	All
66	8043-24	Water inlet Tube	All
67	8043-14	Heating Element (120V, 1500W)	1090, 1092
	8716-1	Heating Element (230V, 3500W)	1091, 1093
68	8043-10	Tank Body	All

### COMPLETE SPARE TANK COVER

8541WF-300	Spare Cover Assembly (120V, 1500W With Coil - all parts mounted to cover)	1090, 1092
8716-300	Spare Cover Assembly (230V, 3800W With Coil - all parts mounted to cover)	1091, 1093

## EXPLODED VIEW & PARTS LIST (continued)

### ELECTRICAL COMPONENTS

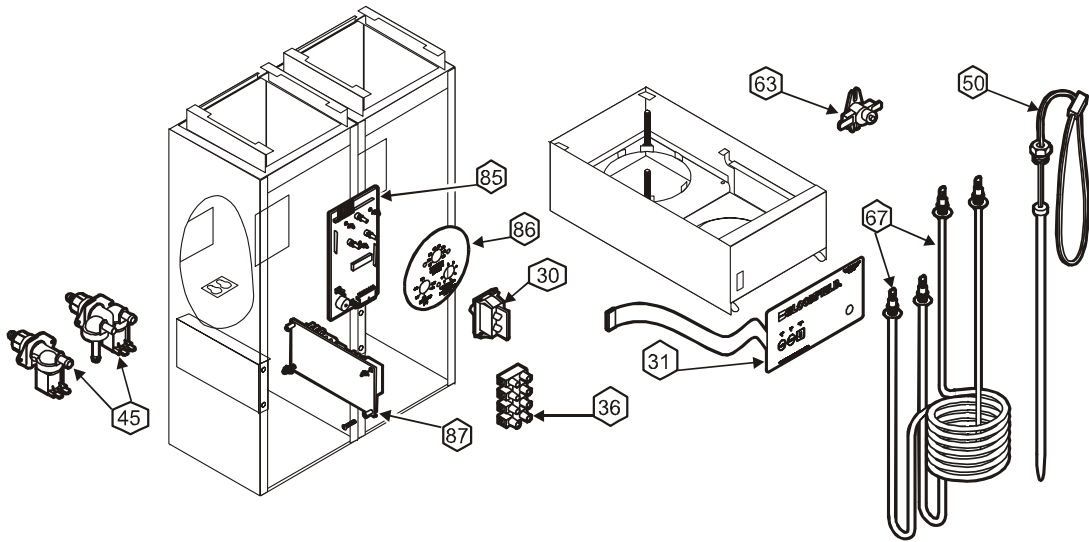

ITEM	PART NO.	DESCRIPTION	USED ON
30	82936	Switch, DPST	1091, 1093
31	1012-10	Keypad	All
36	8552-18	Terminal Strip	All
45	8541-120	Solenoid Valve (old-style)	All
	85753	Solenoid Valve w/Bypass (new-style)	Right Side
	85754	Solenoid Valve, Single (new-style)	Left Side
50	83644	Temperature Probe	All
63	8552-50	Hi-Limit Thermostat	All
67	8043-14	Tank Heating Element 120V / 1500W	1090, 1092
	8716-1	Tank Heating Element 240V / 3500W	1091, 1093
85	1080-226	Controller Board	All
86	1080-40	Controller Dial	All
87	1072-225	Power Board	All

### SOLENOID REPAIR KITS

85218	Inlet Fitting Kit (includes cap, fitting, gasket and strainer)
85219	Inlet Strainer Only

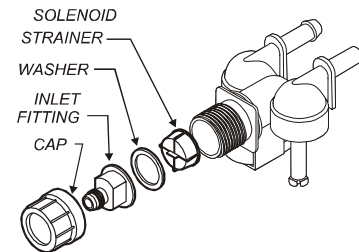

# EXPLODED VIEW & PARTS LIST (continued)

## INTERNAL PLUMBING COMPONENTS

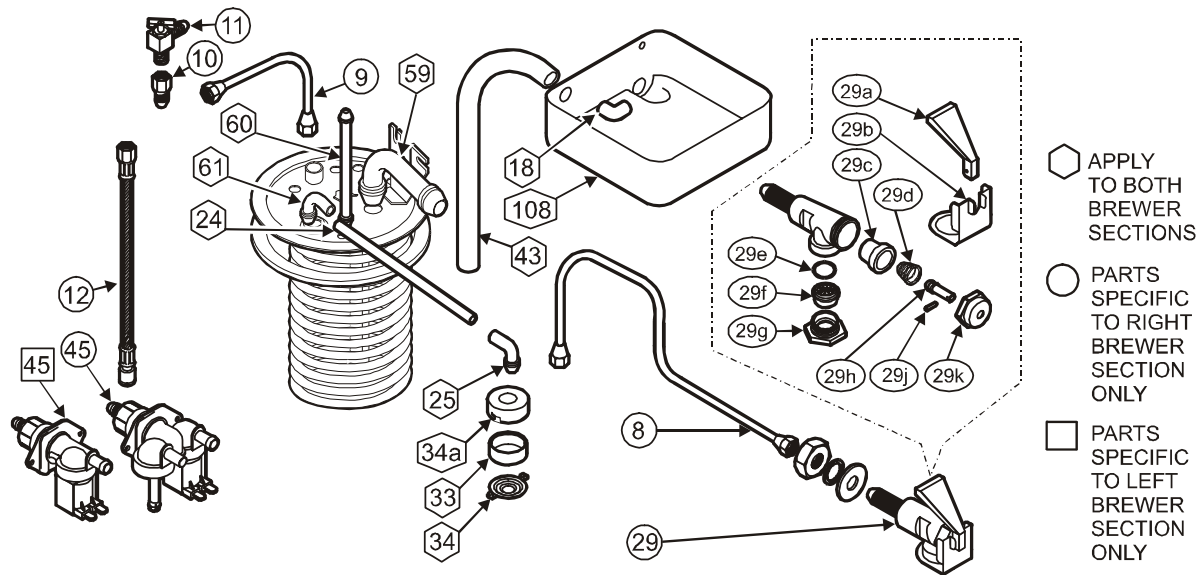

ITEM	PART NO.	DESCRIPTION	USED ON
8	8540-3	Faucet Outlet Tube Assembly	All
10	8551-30	1/4" Male Flare x 1/8" FPT	All
11	8514-26	Needle Valve (Faucet Shut-Off)	All
12	85681	Inlet Tube Assembly	All
18	8540-30	Elbow	All
25	8043-13	Sprayer Elbow	All
29	82556	Faucet Assembly	All
33	8543-42	Spray Head Gasket	All
34	82727	Spray Disk	All
34a	8543-45	Spray Head Retainer	All
43	8541-46	Water Inlet Tube	All
45	85753	Solenoid Valve w/Bypass	Right Side
	85754	Solenoid, Single	Left Side
59	8043-8	Inlet Elbow	All
60	8043-15	Vent Tube	All
61	8043-11	Outlet Elbow	All
108	8541-21	Basin Pan	All
<b>FAUCET REPAIR KITS</b>			
29a	82573	Handle	
29b	82682	Retainer Clip	
29c	82575	Seat Cup	
	82576	Faucet Repair Kit (Includes 29a Handle, 29c Seat Cup, 29d Spring, 29h Stem, 29j Pin & 29k Bonnet)	
	84804	Aerator Replacement Kit (Includes 29e O-Ring, 29f Aerator Disk & 29g Aerator Cap)	
	84870	Aerator Repair Kit (Includes 29e O-Ring & 29f Aerator Disk)	

## EXPLODED VIEW & PARTS LIST (continued)

### CABINET COMPONENTS

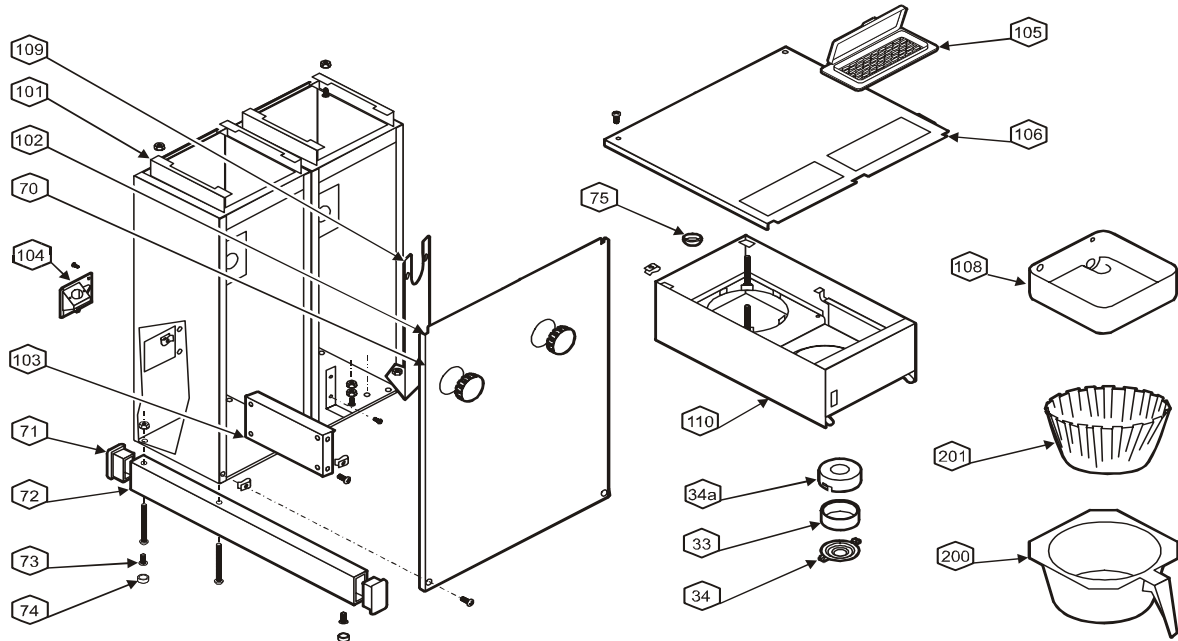

ITEM	PART NO.	DESCRIPTION	USED ON
33	8543-42	Spray Head Gasket	All
34	82727	Spray Disk	All
34a	8543-45	Spray Head Retainer	All
70	8706-75	Button Plug (Timer)	All
71	82159	Cap, Plastic, Lower Support	All
72	82160	Support, Lower (Right)	All
	84718	Support, Lower (Left)	All
73	8033-55	Leveler, Adjustable Leg	All
74	8033-56	Cap, Adjustable Leg	All
	81732	Adjustable Leg Assembly	All
75	8543-69	Heyco Bushing	All
101		Body, Welded Assy	All
102		Front Panel	All
103		Mounting, Power Board	All
104	85089	Access Door, Solenoid	All
105	86666	Cover, Pour-Over	All
106	8542-6	Top Panel	All
108	8541-21	Basin Pan	All
109		Bracket, Hi-Limit Thermostat	All
110		Basin Body, Welded Assy	All
200	8942-6B	Brew Chamber, Black	All
	8942-6	Brew Chamber, Brown	All
	8707-6	Brew Chamber, Stainless	All
210	POF	Bloomfield Paper Filter (pk 1000)	All

# WIRING DIAGRAM

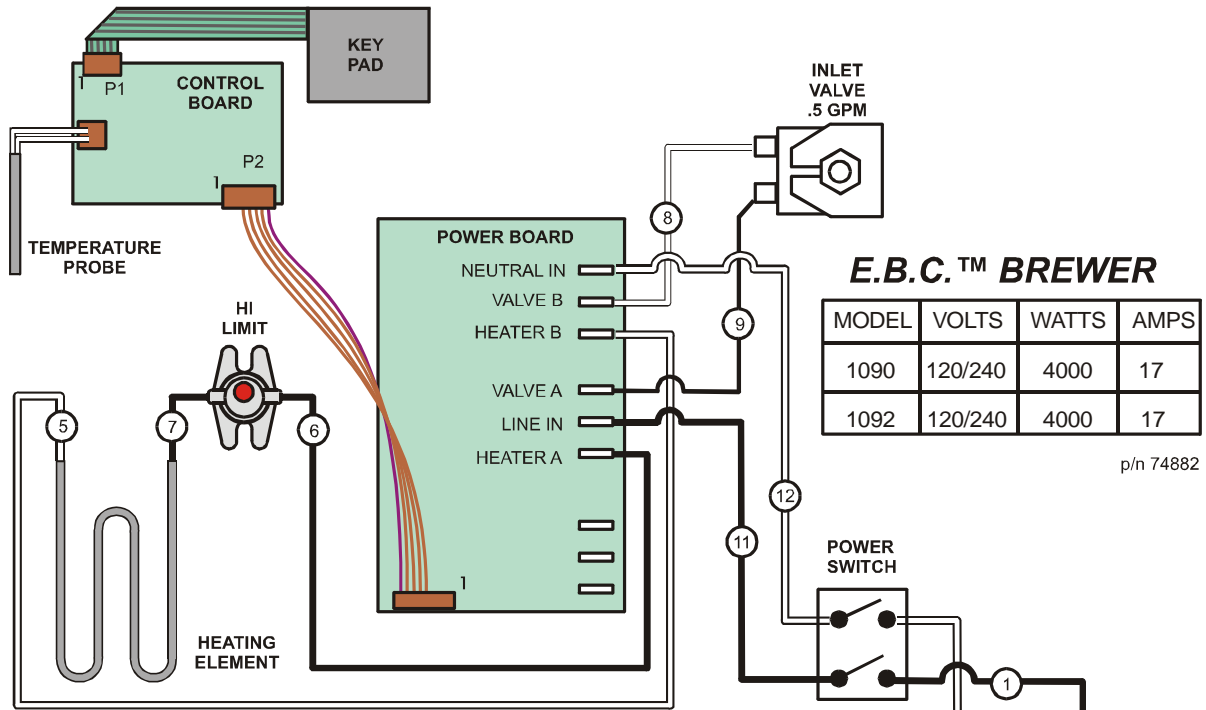

## E.B.C.™ BREWER

MODEL	VOLTS	WATTS	AMPS
1090	120/240	4000	17
1092	120/240	4000	17

p/n 74882

LEFT SIDE

LEFT SIDE

RIGHT SIDE

RIGHT SIDE

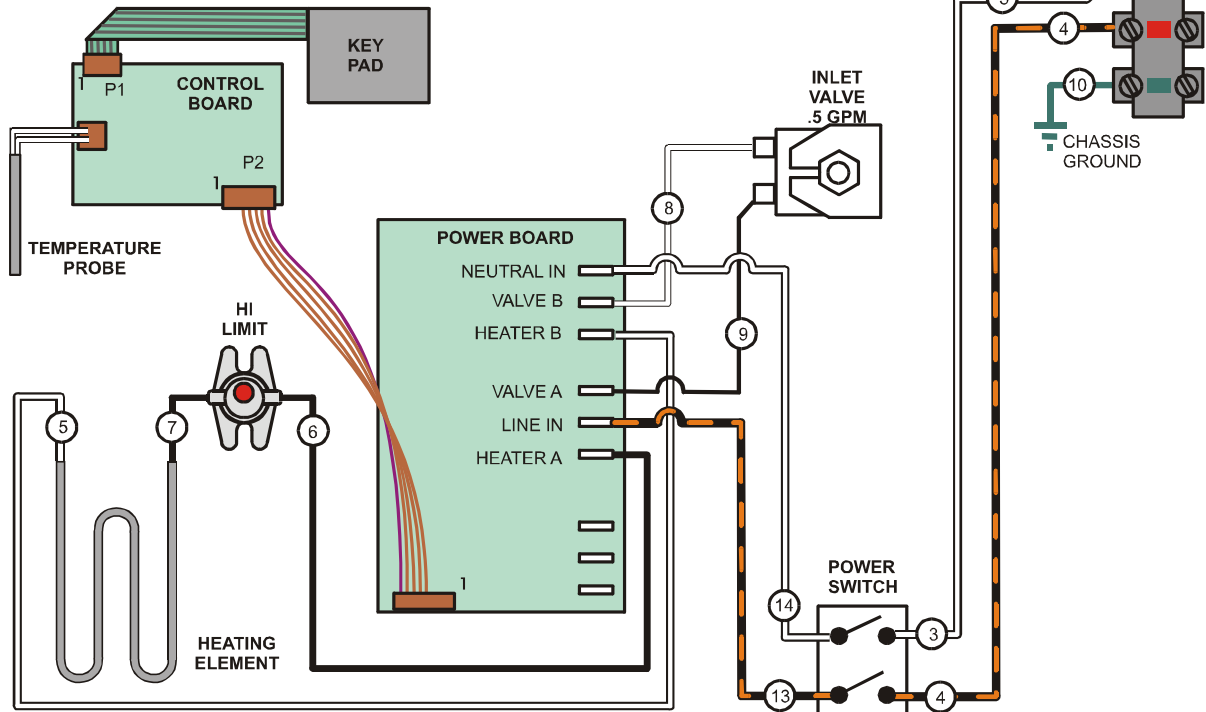

645 75908 Owners Manual E.B.C. Dual Airpot/Thermal Brewer

# WIRING DIAGRAM (continued)

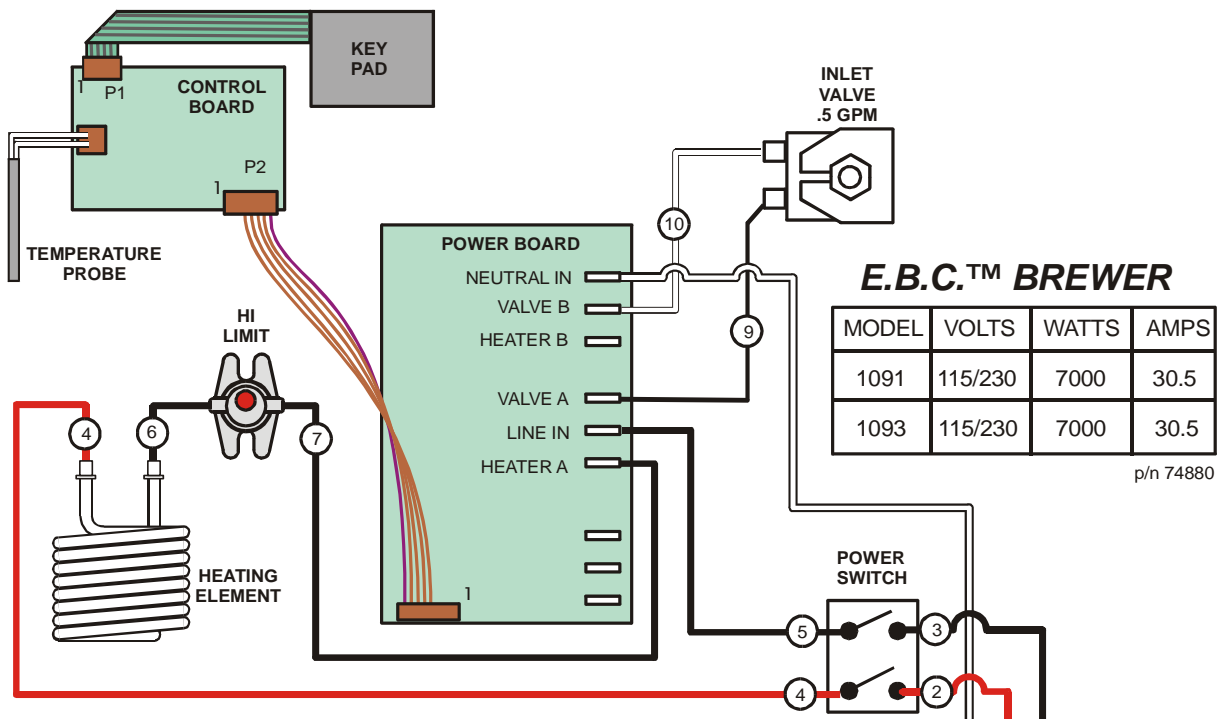

## E.B.C.™ BREWER

MODEL	VOLTS	WATTS	AMPS
1091	115/230	7000	30.5
1093	115/230	7000	30.5

p/n 74880

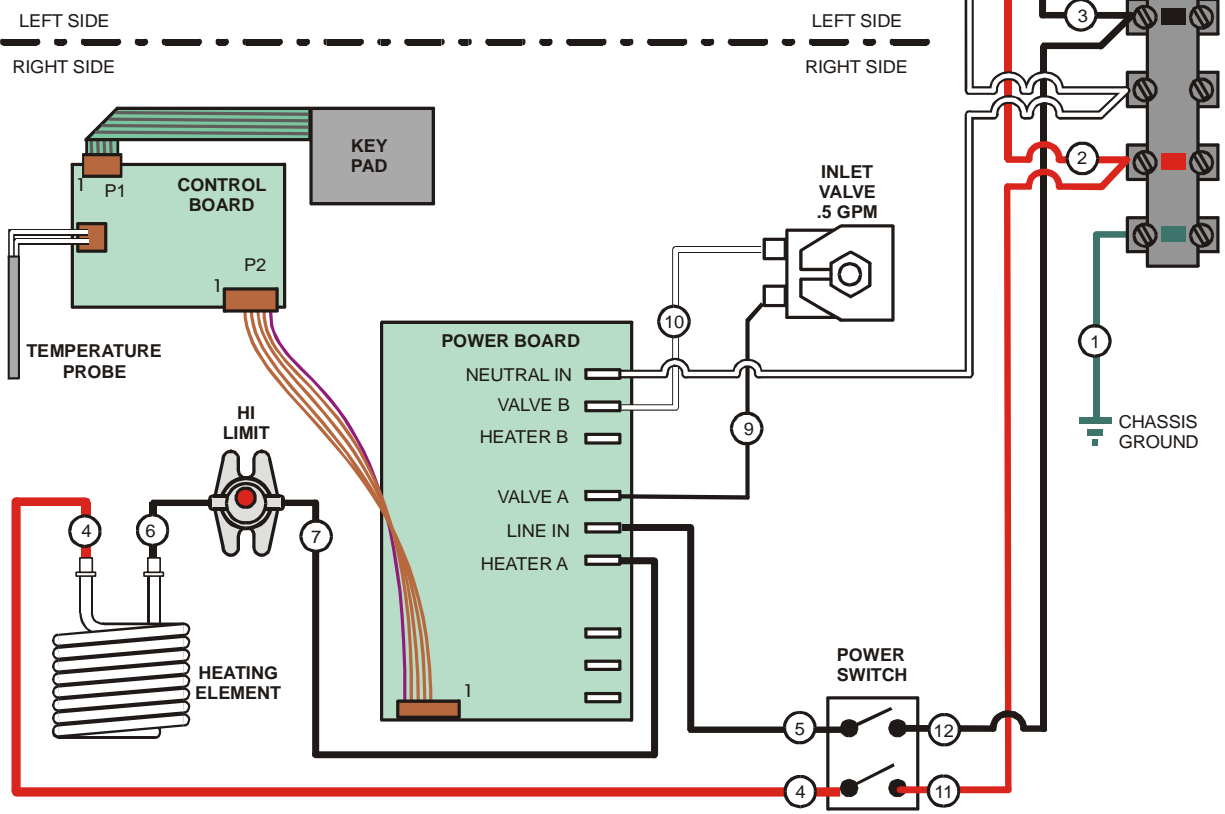

645 75908 Owners Manual E.B.C. Dual Airpot/Thermal Brewer

# CFESA

Commercial Food Equipment Service Association

Bloomfield Industries proudly supports CFESA  
Commercial Food Equipment Service Association

**SERVICE TRAINING - QUALITY SERVICE**



**CUSTOMER SATISFACTION**



**BLOOMFIELD**

**Bloomfield Industries, Inc.**  
**Division of Carrier Commercial Refrigeration**

**In US and Canada**

Telephone: 775-689-5700

Fax: 888-492-2783

Fax: 800-356-5142 (*for orders only*)

website: [www.wellsbloomfield.com](http://www.wellsbloomfield.com)

**PRINTED IN UNITED STATES OF AMERICA**